

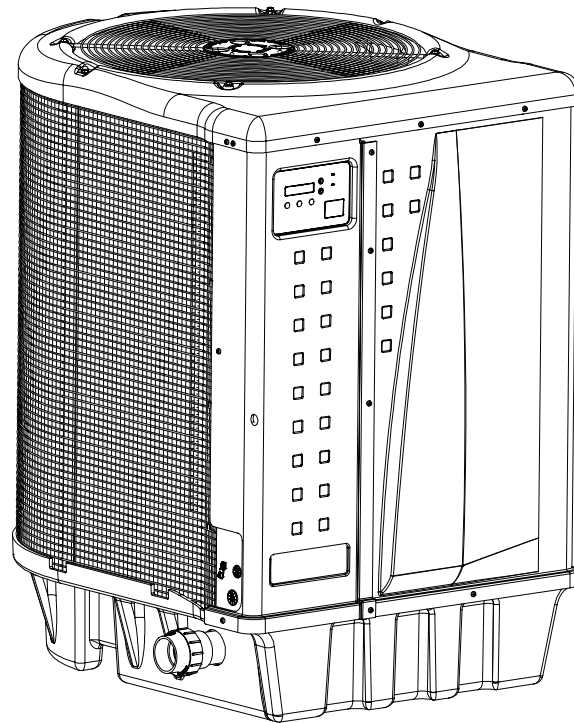

ULTRATEMP[®]

HEAT PUMP



INSTALLATION AND USER'S GUIDE

IMPORTANT SAFETY INSTRUCTIONS
READ AND FOLLOW ALL INSTRUCTIONS
SAVE THESE INSTRUCTIONS

Digital copies of all UltraTemp manuals, as well as translated versions, can be found at www.pentair.com, or by scanning the provided QR code.

Se pueden encontrar copias digitales de todos los manuales de UltraTemp, así como versiones traducidas en www.pentair.com, o escaneando el código QR proporcionado.

Des copies numériques de tous les manuels UltraTemp, ainsi que les versions traduites, peuvent être trouvées sur www.pentair.com, ou en scannant le code QR fourni.



IMPORTANT SAFETY INSTRUCTIONS



Important Notice:

This guide provides installation and operation instructions for this heat pump. Consult Pentair with any questions regarding this equipment.

Attention Installer: This guide contains important information about the installation, operation and safe use of this product. This information should be given to the owner and/or operator of this equipment after installation or left on or near the heat pump.

Attention User: This manual contains important information that will help you in operating and maintaining this heat pump. Please retain it for future reference.



WARNING Before installing this product, read and follow all warning notices and instructions which are included. Failure to follow safety warnings and instructions can result in severe injury, death, or property damage. Call (800) 831-7133 for additional free copies of these instructions.

Codes and Standards

UltraTemp heat pumps are listed by ETL as complying with the latest edition of the “UL Standard for Safety for Heating and Cooling Equipment”, UL 1995 and CSA C22.2 No. 236.

All Pentair heat pumps must be installed in accordance with the local building and installation codes as per the utility or authority having jurisdiction. All local codes take precedence over national codes. In the absence of local codes, refer to the latest edition of the National Electric Code (NEC) in the United States and the Canadian Electric Code (CEC) in Canada for installation.



WARNING RISK OF ELECTRICAL SHOCK OR ELECTROCUTION. The electrical supply to this product must be installed by a licensed, certified electrician or qualified personnel in accordance with the National Electrical Code and all applicable local codes and ordinances. Improper installation will create an electrical hazard which could result in death or serious injury to pool or spa users, installers, or others due to electrical shock, and may also cause damage to property. Read and follow the specific instructions inside this guide.



WARNING This appliance is not intended for use by persons with reduced physical, sensory or mental capabilities, or lack of experience and knowledge, unless they have been given supervision or instruction concerning use of the appliance by a person responsible for their safety. Do NOT permit children to use this product.



WARNING For units intended for use in other than single-family dwellings, a clearly labeled emergency switch shall be provided as part of the installation. The switch shall be readily accessible to the occupants and shall be installed at least 5 ft [1.5 m] away, adjacent to, and within sight of the unit.

Consumer Information and Safety

The UltraTemp series of heat pumps are designed and manufactured to provide safe and reliable service when installed, operated and maintained according to the information in this manual and the installation codes referred to in later sections. Throughout the manual, safety warnings and cautions are identified by the “▲” symbol. Be sure to read and comply with all of the warnings and cautions.



WARNING The U.S. Consumer Product Safety Commission warns that elevated water temperature can be hazardous. See below for water temperature guidelines before setting temperature.



WARNING The following “Safety Rules for Hot Tubs” recommended by the U.S. Consumer Product Safety Commission should be observed when using the spa.

1. Spa or hot tub water temperatures should never exceed 104°F [40°C]. A temperature of 100°F [38°C] is considered safe for a healthy adult. Special caution is suggested for young children. Prolonged immersion in hot water can induce hyperthermia.
2. Drinking of alcoholic beverages before or during spa or hot tub use can cause drowsiness which could lead to unconsciousness and subsequently result in drowning.
3. **Pregnant women beware!** Soaking in water above 100°F [38°C] can cause fetal damage during the first three months of pregnancy (which may result in the birth of a brain-damaged or deformed child). Pregnant women should stick to the 100°F [38°C] maximum rule.
4. Before entering the spa or hot tub, the user should check the water temperature with an accurate thermometer. Spa or hot tub thermostats may err in regulating water temperatures.
5. Persons with a medical history of heart disease, circulatory problems, diabetes or blood pressure problems should obtain their physician’s advice before using spas or hot tubs.
6. Persons taking medication which induce drowsiness, such as tranquilizers, antihistamines or anticoagulants should not use spas or hot tubs.

Hyperthermia occurs when the internal temperature of the body reaches a level several degrees above normal body temperature of 98.6°F [37°C]. The symptoms of hyperthermia include: drowsiness, lethargy, dizziness, fainting, and an increase in the internal temperature of the body.

The effects of hyperthermia include:

1. Unawareness of impending danger.
2. Failure to perceive heat.
3. Failure to recognize the need to leave the spa.
4. Physical inability to exit the spa.
5. Fetal damage in pregnant women.
6. Unconsciousness resulting in danger of drowning.

General Specifications

Installation Location Certified for use:

OUTDOOR USE ONLY. Failure to provide the proper clearances outlined on page 3 will lower the performance of the heat pump and void the warranty.

Water Pipe/Heater Connection — Plastic 2” [50 mm] PVC (Unions included)

Flow Rate

- Maximum 120 gpm [456 lpm] - If system flow rate exceeds 120 gpm [456 lpm], a bypass valve is required
- Minimum 30 gpm [110 lpm]
- Maximum Working Water Pressure 50 psi [3.5 bar]

For Electrical Supply and Voltage Requirements, refer to the table on page 25.

CUSTOMER SERVICE / TECHNICAL SUPPORT

Hours: 8:00AM to 7:30PM EST (5:00AM - 4:30PM PST)

Call: (800) 831-7133

Visit: www.pentair.com

Fax: (800) 284-4151

TABLE OF CONTENTS

IMPORTANT SAFETY INSTRUCTIONS	i	OPERATING THE HEAT PUMP	16
MENU TREE QUICK START GUIDE	iii	Swimming Pool Energy Saving Tips	16
BEFORE INSTALLING THE HEAT PUMP	1	Heat Pump Control Panel Overview	16
Heat Pump Overview	1	Operator Menu Tree Guide	17
Installation Requirements	1	Starting and Stopping the Heat Pump	18
General Installation Information	1	Changing the Set Point - Pool and Spa	18
General Features	1	Heat, Cool, and Auto Modes	18
INSTALLATION AND LOCATION	2	Heat Pump Timer	18
Materials Required for Installation	2	Relay Remote	18
Equipment Pad	2	RS-485 Remote (Serial Cable)	18
Drainage and Condensation, Roof Run Off, and Lawn Sprinklers	2	AutoSet Operation	19
Heat Pump Dimensions	2	Extend Operation	19
Location and Clearances	3	Timers and Delays	20
Anchor Clamp Installation	3	Control Panel Alarm Messages	20
Water Connections and Plumbing	4	Service Menu Tree Guide	21
Automatic Flow Control Valve	4	Setting Temperature Scale	22
Water Connections to the Heat Pump	5	Set Water Temperature Offset	22
Drainage Connection to the Heat Pump	5	Defrost Cycle	22
Water Pressure Switch Adjustment	6	Run Time Counters	22
Multiple Unit Installation	7	Locking the Control Panel	22
Heat Pump, Heater, Solar Combination	7	MAINTENANCE	23
Multiple Heat Pump Connections	7	Water Chemistry	23
Electrical Connections and Wiring	9	Winterizing	23
Wiring Diagram – (Single Phase – 50/60 Hz)	10	Spring Start Up	23
Wiring Diagram – (Three Phase – 60 Hz)	11	Inspection and Service	23
CONNECTING TO AN AUTOMATION SYSTEM ...	12	Owner Inspection	24
Remote Operation	12	Professional Maintenance and Service	24
Relay Remote Controls	12	TECHNICAL INFORMATION	25
Connecting to IntelliTouch or EasyTouch via Heat Pump Spade Terminals	13	Electrical Supply - Voltage Requirements	25
Connecting to IntelliTouch or EasyTouch via RS-485 Connector	14	Temperature Resistance Chart	25
Pin Configuration for Heat Pump Control Board to IntelliTouch	15	Ambient/Water Flow Table for Professional Maintenance and Service	26
Connecting IntelliTouch or EasyTouch to the Heat Pump	15	Heat Pump Pressure Drop	26
		TROUBLESHOOTING	27
		REPLACEMENT PARTS	32
		Illustrated Parts View	32
		Parts List	33

For pool energy saving tips, refer to page 16, under “Operating the Heat Pump”. For technical data, voltage requirements, or ambient/water flow information, refer to page 25 at the back of the manual.

ULTRATEMP® MENU TREE QUICK START GUIDE

1. Push the ON/OFF button to turn the unit on, the green “ON” light should be lit.
2. Select either Pool or Spa mode. The default is Pool mode.
3. Adjust the temperature to the desired setting by pushing either the UP arrow or DOWN arrow.
4. Allow 5 minutes for compressor restart delay.

See pages 17-22 for details on the Operator and Service menu screens on the control panel.

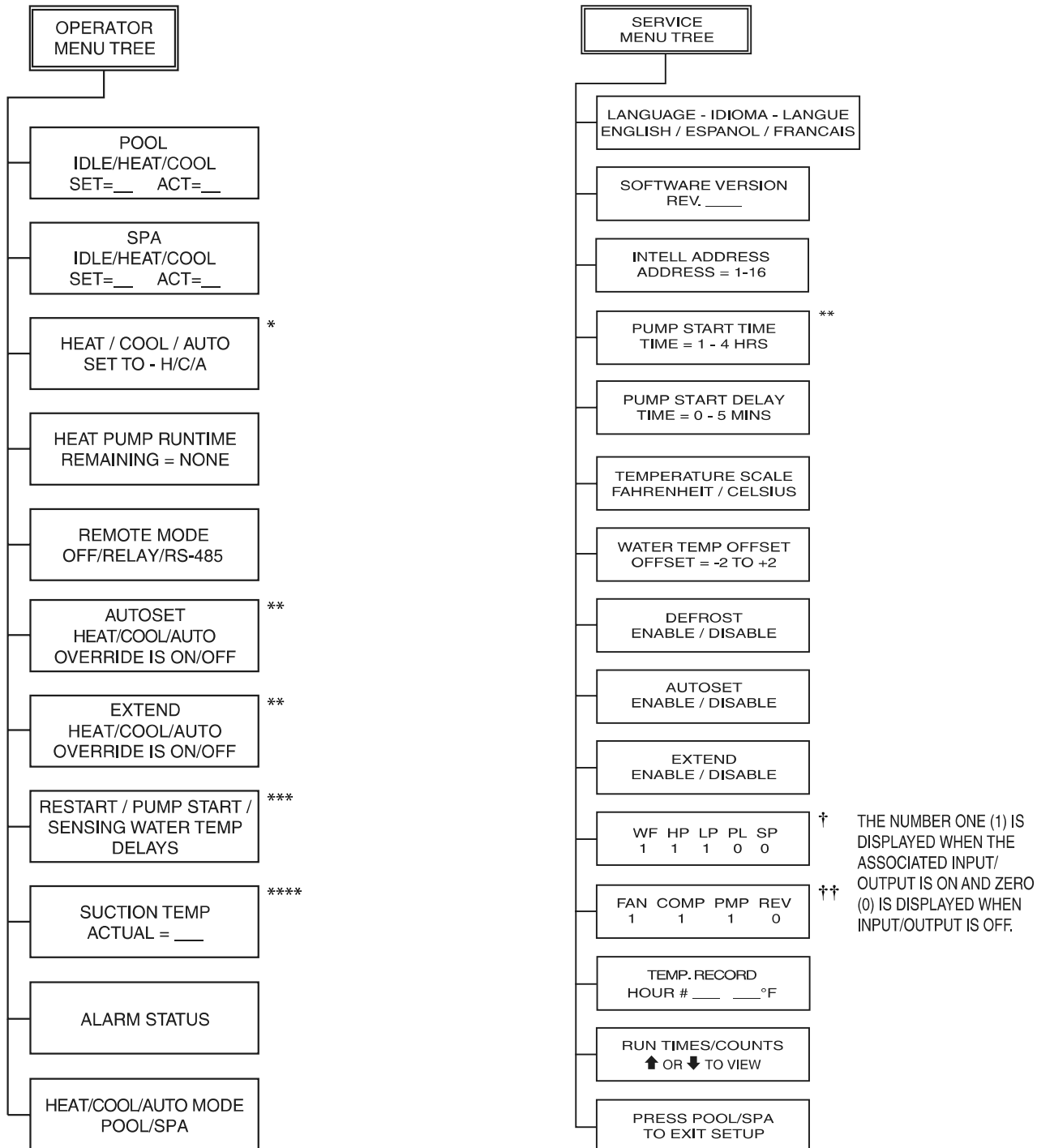

- * Menu appears only if Heat and Cool mode is enabled at the factory.
- ** Menu appears only if AutoSet or Extend is enabled in the Service menu.
- *** Menu appears only if a delay is active.
- **** Menu appears only if Defrost is enabled in the Service menu.

- † **INPUT STATUS**
- WF = WATER FLOW SWITCH
 - HP = HIGH REFRIGERANT PRESSURE SWITCH
 - LP = LOW REFRIGERANT PRESSURE SWITCH
 - PL = POOL REMOTE
 - SP = SPA REMOTE

- †† **OUTPUT STATUS**
- FAN - FAN
 - COMP - COMPRESSOR
 - PMP - FILTER PUMP
 - REV - REVERSING VALVE

BEFORE INSTALLING THE HEAT PUMP

Heat Pump Overview

Your Pentair heat pump will provide you with years of heated pool enjoyment. Heat pumps operate by taking heat from the surrounding air and transferring it into the water. The warmer the air and the more humidity in the air, the more latent heat is available for heating your pool. With a properly sized heat pump for your pool, the heat pump should raise your pool on average 1°F (-17°C) per hour depending on air temperature, humidity, and water temperature. The ideal or rated condition for the heat pump is 80°F (27°C) air temperature, 80% relative humidity, and 80°F (27°C) water temperature. As conditions decrease from 80/80/80, the heat pump performance will decrease slightly.

Heat Pumps are best utilized to maintain a set water temperature; they are not intended to provide instant or fast heating. It is not reasonable to expect a heat pump to perform like a gas heater which has a much higher BTU output and faster response. Additionally, gas heaters are not dependent on environmental conditions. Swimming pool heat pumps are very similar to home heating and air conditioning heat pumps and therefore should be treated similarly.

Proper operation and use of the heat pump is to set it at your desired temperature and leave it. Your heat pump will turn on and off automatically to maintain your desired temperature much like your home HVAC unit. To take advantage of the sun's energy, operate your heat pump during the heat of the day.

Your heat pump will still operate when the temperature drops at night, but the output will be decreased. It is acceptable to shut the heat pump off and not use it for extended periods of time. When you have a need to heat your pool, please plan accordingly since it may take the heat pump days to heat your pool back to your desired temperature, depending on your pool temperature and environmental conditions.

Heat Pump Installation Requirements

Correct installation is required to assure safe operation. The requirements for Pentair heat pumps include the following:

- Dimensions for critical connections.
- Field assembly (if required).
- Appropriate site location and clearances (pages 2-3).
- Proper electrical wiring (pages 9-11).
- Adequate water flow (page i).

This manual provides the information needed to meet these requirements. Review all application and installation procedures completely before continuing the installation.

General Installation Information

1. Installation and service must be performed by a qualified installer or service agency, and must conform to all national, state, and local codes.
2. Heat pumps get electrical power from an external source and provide a dual electronic thermostat control system for pool/spa combinations or preheat convenience.
3. This heat pump is specifically designed for heating fresh water swimming pools and spas. Do not use it as a general service heater. Consult your dealer for the appropriate Pentair products for these applications.

General Features

- Dual digital thermostats offer precise temperature control to maintain the desired separate water temperatures in pool/spa combinations without overheating or wasting energy.
- Long-life corrosion resistant composite plastic cabinet stands up to severe climates and pool chemicals.
- 100% pure titanium heat exchanger assures corrosion-free performance for extra long life.
- Self-diagnostic control panel monitors and troubleshoots heat pump operations to ensure safe, dependable operation.
- Autoset (time clock over-ride) feature monitors water temperature and turns the water circulation pump on and off as needed to maintain desired pool temperatures.
- Extend (time clock over-ride) feature monitors water temperature and turns the water circulation pump on and off as needed to prolong a heating cycle that has been interrupted.
- Automatic Defrost feature senses refrigerant temperature and prevents the heat pump from freezing, allowing the heat pump to operate at even lower temperatures.
- Compatible with all automated control packages. RS-485 communication compatible with IntelliTouch® and EasyTouch® Control Systems.
- Thermostatic expansion valve (TXV) controls refrigerant flow for optimum efficiency and BTU output over a wider operating range.
- Elevated base pan for positive drainage of condensation.
- 2-inch plumbing connections for easy installation.
- Separate isolated electrical compartment prevents internal corrosion, extends heater life.
- Highest efficiency available, meets or exceeds existing codes and standards.
- Adjustable timer allows the operator to set the heat pump to run for a predetermined time. Incremental by 10 minutes to a maximum of 99 hours.
- An extensive list of operational conditions, alarms and water temperatures are logged on the control board. This information is available for the user to track performance and troubleshoot issues.

INSTALLATION AND LOCATION

⚠ CAUTION

When pool equipment is located below the pool surface, a leak from any component can cause large scale water loss or flooding. Pentair Water Pool and Spa, Inc. cannot be responsible for such water loss or flooding which may cause damage to property or to the product. Avoid placing the heat pump in locations where it can cause damage by water or condensate leakage. If this is not possible, provide a suitable drain pan to catch and divert any leakage.

Only a qualified service person should install the UltraTemp® Heat Pump. Before installing this product, refer to *IMPORTANT SAFETY INSTRUCTIONS* on page i.

Materials Required for Installation

The following items are needed and are to be supplied by the installer for all heat pump installations:

1. Plumbing connections (2-inch).
2. Level surface for proper drainage.
3. Suitable electrical supply line. See rating plate on unit for electrical specifications. A junction box is not needed at the heat pump; connections are made inside of the heat pump electrical compartment. Conduit may be attached directly to the heat pump jacket.
4. Electric cutout switch that will interrupt all power to the unit. This switch must be within line of sight of the heat pump. Check local codes for requirements.
5. Watertight conduit to run the electrical supply line.

Equipment Pad

For proper drainage of condensation and rain water, place the heat pump on a flat slightly pitched surface, such as a concrete or fabricated slab (pad).

If possible, place the pad at the same level or slightly higher than the filter system equipment pad.

Note: Be sure that the pad is pitched not more than 1/4 in. per foot in any direction as needed for runoff.

Drainage and Condensation

Condensation occurs from the evaporator coil while the unit is running, and drains at a steady rate (usually three to five gallons per hour), depending upon ambient air temperature and humidity. The more humid the ambient conditions, the more condensation will be produced.

The bottom of the unit acts as a tray to catch rainwater and condensation. Keep the drain holes, located on the bottom pan of the base of the unit, clear of debris.

Roof Run-off

Make sure the heat pump is not located where large amounts of water may run-off from a roof into the unit.

Sharp sloping roofs without gutters will allow massive amounts of rain water, mixed with debris from the roof to be forced through the unit. A gutter or down spout may be needed to protect the heat pump.

Lawn Sprinklers

Avoid placing lawn sprinkler near the heater - they can spray water into the heater and void the warranty.

Be sure to direct any spraying water away from the heater. Note the wind direction to be sure water from sprinklers is not blown toward the heater. Sprinkler heads can produce high water pressure and spray at an angle, different from typical rain and humid weather. Also, sprinklers connected to a well water system can cause mineral build up on the evaporator coils and electronics. Salt water can also be an issue if located near the coast.

Heat Pump Dimensions

MODELS	DIMENSION "A"
70, 90	33.5" (851 mm)
110, 120, 120C, 140C 120 H/C, 140, 140 H/C	45.5" (1156 mm)

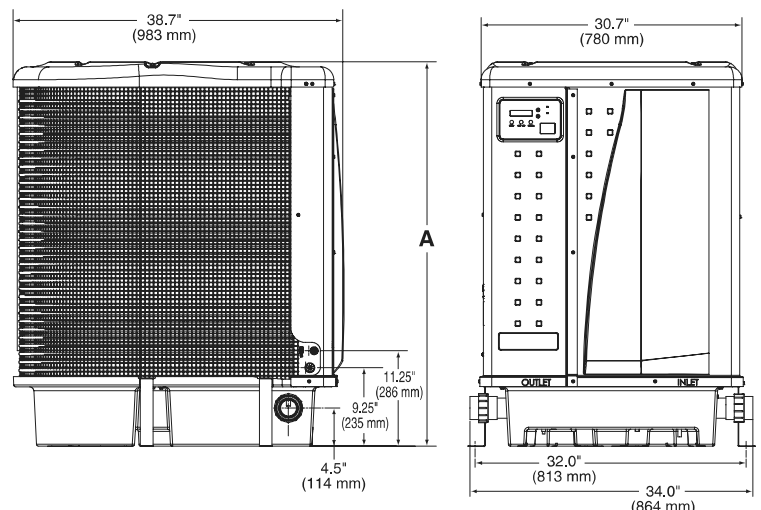

Location and Clearances

All criteria given in the following sections reflect minimum clearances. However, each installation must also be evaluated, taking into account the prevailing local conditions such as proximity and height of walls, and proximity to public access areas.

The UltraTemp® Heat Pump must be placed to provide clearances on all sides for maintenance and inspection.

1. At least 24 in. [610 mm] access must be available in the front and 12 in. [305 mm] on all the other sides of the heat pump for service and proper air flow. (Manufacturer's recommendation).

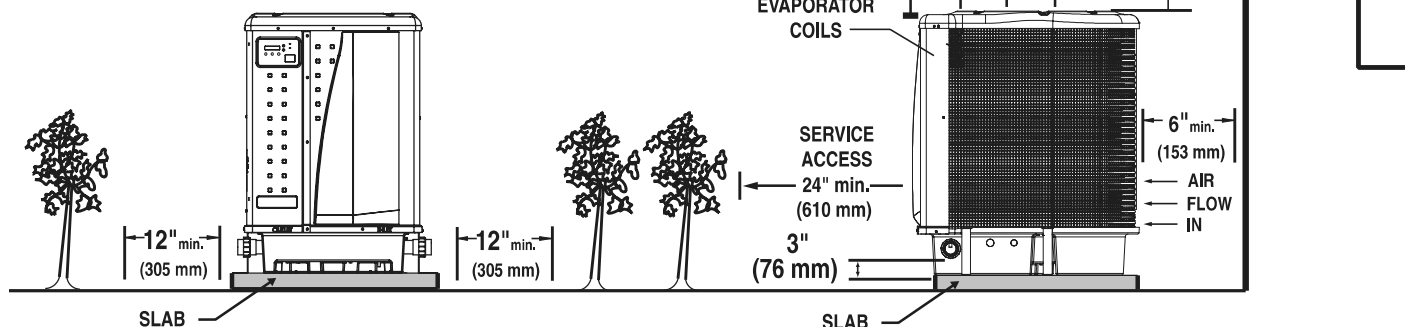
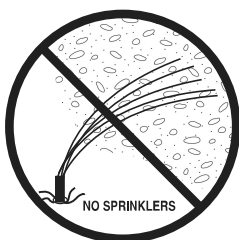

Heat Pump Location and Clearances

Anchor Clamp Installation

Installation of the anchor clamps is recommended in all installations. Installation of the anchor clamps is required in Florida (see Florida Building Code 301.13).

Anchor clamps hold the heat pump to the equipment pad in order to withstand high winds caused during extreme weather (i.e. hurricanes).

To install the anchor clamps:

1. Be sure the heat pump is in its permanent location on the equipment pad.
2. Place the clamps at the base of the heat pump in the four (4) locations, shown in the image to the right.

Note: Bolts and bolt anchors are not included with the heat pump. The installer must provide 1/4" x 1-3/8" stainless steel anchor bolts and the appropriate size concrete anchor to mount the clamp to the equipment pad. Be sure to check local codes.

3. Fit the hook of each clamp over the lip on the base panel of the heat pump. The hook should fit between the lip of the base panel and the evaporator coil guard.

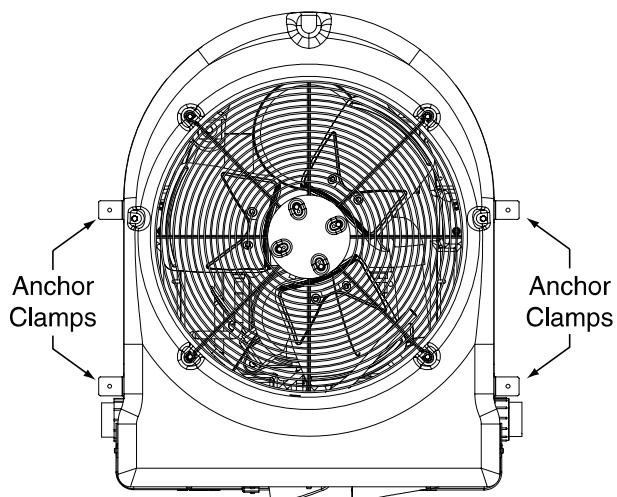

Anchor Clamp Installation

2. If the heat pump is to be installed under a cover or under a vertical overhang, the unit must have a minimum of five (5) feet [1.52 m] clearance from the top of the heat pump. (Manufacturer's recommendation).
3. Install a minimum of five (5) feet [1.52 m] from the inside wall of the pool or spa unless the heat pump is separated from the pool or spa by a five (5) foot [1.52 m] high solid fence or other permanent barrier. Canadian installations require a minimum of three (3) meters [9.84 ft] from pool water.
4. Install heat pump a minimum of 6 in. [153 mm] from the wall of the house.

Anchor Clamp Installation, Continued

4. Mark the position of the hole in each clamp on the equipment pad.
5. Use a masonry drill bit and drill a hole in the cement with a diameter as determined by the concrete anchor, at each of the marks on the equipment pad. The hole should be approximately 1/2-in. deep.
6. Insert a bolt anchor into each of the holes. Be sure the anchors are set completely into the holes.
7. Position the anchor clamps so that the holes in the clamps are over the bolt anchors.
Be sure that the clamp hooks are over the lip of the heat pump base.
8. Insert an anchor bolt through each clamp into the anchor and tighten to secure the clamp and heat pump to the equipment pad.

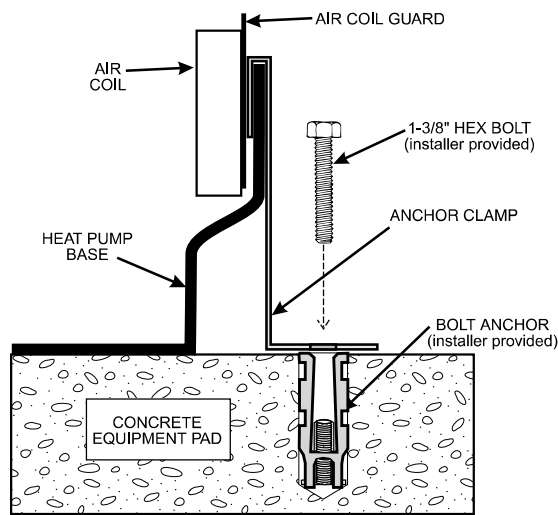

Anchor Clamp Installation

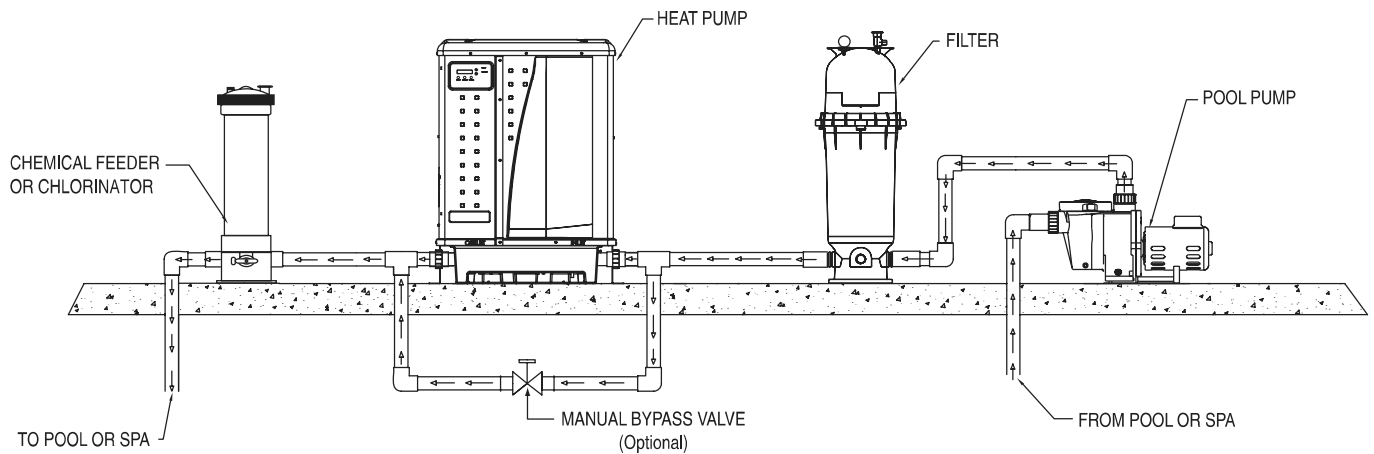

Standard Plumbing Layout

Water Connections and Plumbing

The image below shows the standard plumbing layout with a single UltraTemp® Heat Pump. Follow the image from right to left for the standard plumbing sequence.

Arrangement of pool system components (other than the standard plumbing image below), and the location of the heat pump (above or below the pool water surface) can affect the operation of the heat pump's water pressure switch.

The pressure switch can be adjusted to accommodate this effect if the heat pump water connections are no more than six (6) feet [1.8 m] below the pool water surface.

See instructions for pressure switch adjustment on page 6. If the heat pump is installed outside of this range, an external pressure switch may need to be installed in the plumbing upstream of the heat pump.

Note: Be advised that when pool equipment is located below the pool surface a leak can result in large-scale water loss or flooding. Pentair is not responsible for such water loss or flooding or damage.

Automatic Flow Control Valve

The inlet/outlet header of the heat pump comes equipped with an internal automatic flow control valve. The automatic flow control valve maintains the proper flow through the heat pump at rates up to 120 gpm (456 lpm). If the filter system flow rate is higher than 120 gpm (456 lpm), install a manual bypass valve, see image below.

Note: Be advised that if your circulation pump is over 2 HP or if the total flow exceeds 120 gpm (456 lpm), you will have to add an external bypass valve. Excess water flow will damage the heat exchanger.

Water Connections to the Heat Pump

2 in. Quick Connect fittings have been installed on the water inlet and outlet connections. Filtered cool water is plumbed to the inlet, located on the right side of the UltraTemp® Heat Pump. Heated water flows through the outlet, located on the left side of the heat pump.

Plastic piping (PVC Schedule 40) should be connected to the heat pump. The unions, provided with the unit, accept 2" PVC pipe.

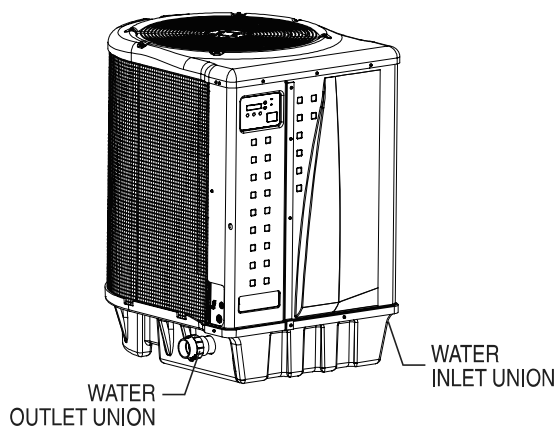

Heat Pump Water Connections

CAUTION

Always be sure that flow requirements and pool water turnover rates can be maintained with the installation of additional heat pumps and plumbing restrictions.

Drainage Connection to the Heat Pump

A 5/8" x 1/2" NPT threaded drain hose barb is included with the heat pump union kit.

Before operating the heat pump for the first time, the drain hose barb must be installed into the threaded drainage outlet located in the base of the heat pump.

To install the Drain Hose Barb and Drain Hose:

1. Thread the drain hose barb into the threaded drainage outlet in the base of the heat pump. See the image below.
2. Connect a 5/8" garden hose to the hose barb.
3. Ensure the end of the garden hose is positioned so that drainage will flow away from the heat pump and equipment pad.

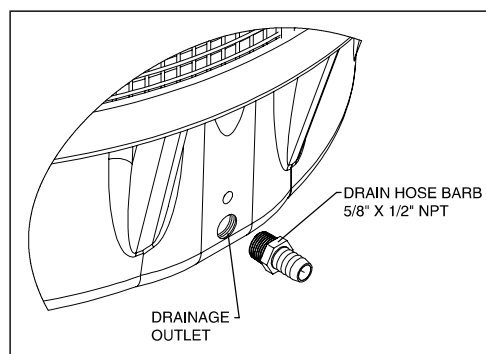

Drain Hose Barb Installation

Water Pressure Switch Adjustment

CAUTION The water pressure switch should be adjusted to turn the heater off when the pump is off. Setting the switch to close at too low of a flow can damage the appliance. Adjust the switch to turn the heater off, not on.

The pressure switch is preset at the factory for activation at 1.5 psi [10 kPa]. This factory setting works for most basic installations. Only adjust the water pressure switch if the heat pump does not operate **when the proper flow is applied to unit** or if the heat pump does not shut off when the filter pump is off. Occasionally, unusual plumbing configurations or necessary restrictions in the plumbing may cause pressure sensing problems. In these rare situations, the plumbing system configuration may require adjustment of the water pressure switch.

Adjustment of the pressure switch may be necessary if any part of the filter system piping is 3 feet [0.9 m] or more above the top of the heat pump.

In general, if the heat pump is installed more than 6 feet [1.8 m] below the pool surface, an external water flow switch must be added to the plumbing system.

On some installations, the piping from the heat pump to the pool is very short. The back pressure could be too low to trigger the pressure switch. If this happens, install a directional fitting or elbow where the return line enters the pool. This will increase back pressure for the heat pump to operate properly. Be sure to check that the system flow is above the minimum requirement of 30 gpm (110 lpm) after the directional fitting installation.

Be sure the pool filter is clean before making any pressure switch adjustment: A dirty filter will restrict the water flow and the pressure switch cannot be adjusted properly.

To adjust the pressure switch:

The following adjustment is for installations where the heat pump is *below* pool water level.

1. Be sure that all valves in the system are set to allow water flow through the heat pump. Start the filter pump.
2. Set the heat pump temperature above the actual temperature to call for heat. Turn the heat Pump ON.
3. Once the heat pump is running, turn off the filter pump. The heat pump should turn off immediately.
4. If the heat pump continues to operate when the filter pump is off, then the water pressure switch needs to be adjusted.
5. Remove the heat pump's left front panel and remove remaining right front panel. The water pressure switch is located in the water plumbing in the lower right corner of the heat pump.

6. Slowly rotate the adjustment wheel on the water pressure switch in a clockwise direction until the "LOW WATER FLOW" Alarm shows on the LCD, the red SERVICE light turns ON, and the heat pump stops.
7. Check the setting of the water pressure switch by starting and stopping the filter pump and checking the control panel and operation of the heater between each flow change.
8. If the water pressure switch cannot be adjusted to accommodate the conditions listed above, an external flow switch must be added to the plumbing system to ensure that the heat pump will not operate without the proper flow through the heat exchanger.

The following adjustment is for installations where the heat pump is *above* pool water level.

1. Be sure that all valves in the system are set to allow water flow through the heat pump. Start the filter pump.
2. Set the heat pump temperature above the actual temperature to call for heat. Turn the heat pump ON.
3. If the LCD shows a "LOW WATER FLOW" Alarm and red SERVICE light is present then the water pressure switch needs to be adjusted.
4. Remove the UltraTemp® Heat Pump's left front panel and remove remaining right front panel. The water pressure switch is located in the water plumbing in the lower right corner of the heat pump.
5. Slowly rotate the adjustment wheel on the water pressure switch in a counterclockwise direction until the "LOW WATER FLOW" Alarm and red SERVICE light vanish, time delay countdown will start.
6. Once the heat pump is running, turn off the filter pump. The heat pump should turn off immediately.
7. If the heat pump continues to operate when the filter pump is off, turn the adjustment wheel on the water pressure switch in a clockwise direction until the "LOW WATER FLOW" Alarm shows on the LCD, the red SERVICE light turns ON, and the heat pump stops.
8. Check the setting of the water pressure switch by starting and stopping the filter pump and checking the control panel and operation of the heater between each flow change.
9. If the water pressure switch cannot be adjusted to accommodate the conditions listed above, an external flow switch must be added to the plumbing system to ensure that the heat pump will not operate without the proper flow through the heat exchanger.

Multiple Unit Installation

1. Heat Pump, Heater and/or Solar Combination

In certain regions of the country it may be more economical to run a UltraTemp® Heat Pump during the warmer months and a gas heater during the cooler months. In some situations it may be desirable to run the heat pump in the “Chiller” mode, if so equipped, during the hottest portion of the year and a heater during the cooler months. The Pentair heat pump may be used in conjunction with a gas or electric heater or any combination of heat sources including solar. All heat sources must be plumbed in series to work correctly and efficiently.

A recommended plumbing layout for a heat pump / heater / solar combination heating system for a pool / spa combination is shown below. Your system may not contain all of these components, but the basic plumbing will apply by eliminating the component in the illustration that is not a part of your system.

2. Multiple Heat Pump Connections

All plumbing on multiple heat pump installations must be done in parallel (see next page). An equal flow of water to each heat pump is important for optimum operation.

Note: It may be necessary to adjust the water pressure switch if a unit is installed below the water level. Refer back to page 6 for details on when and how to adjust the pressure switch.

Each heat pump in a multiple unit installation allows a maximum flow rate of 100 gpm (380 lpm) and requires a minimum of 30 gpm (110 lpm).

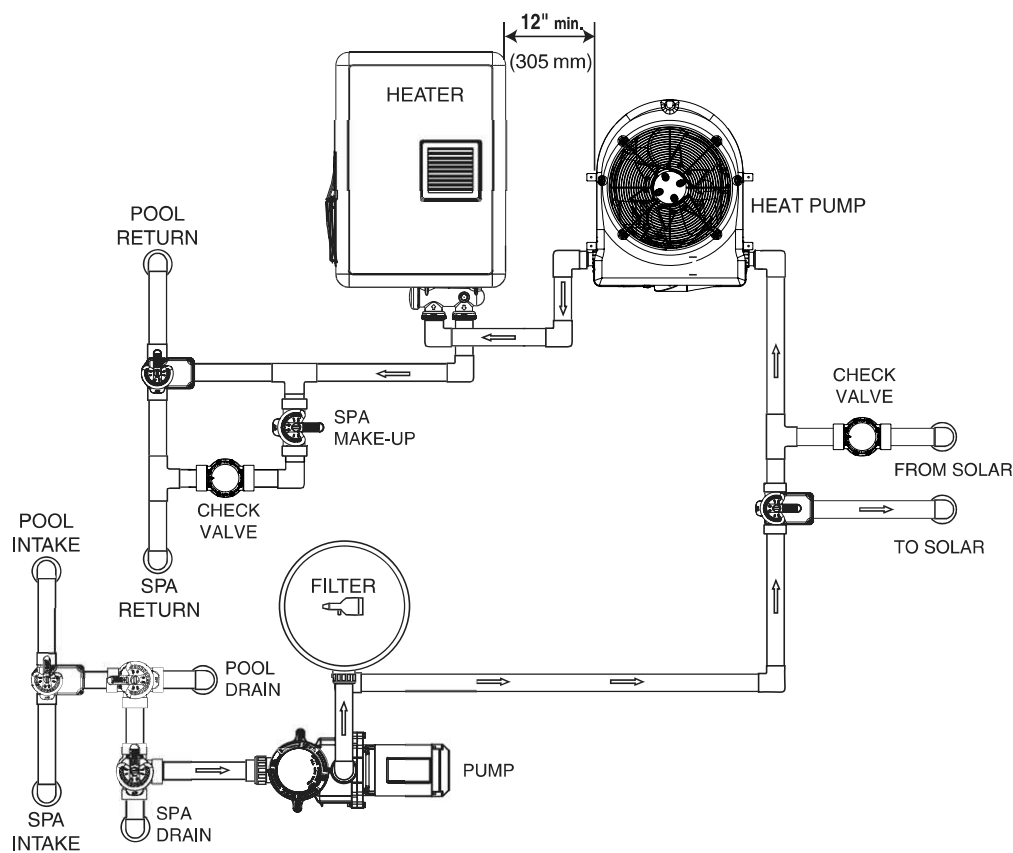

Heater and/or Solar Combination

Multiple Unit Installation (cont.)

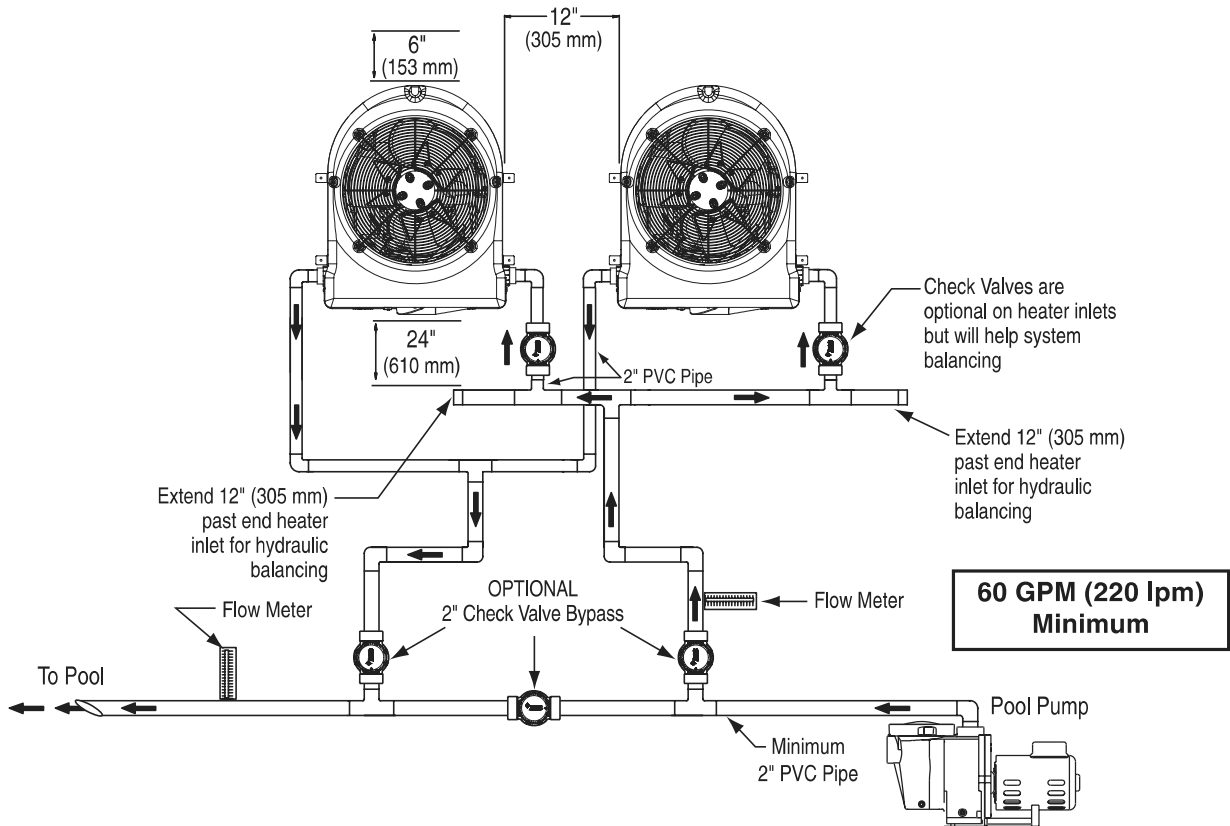

Two Heat Pump Plumbing Layout

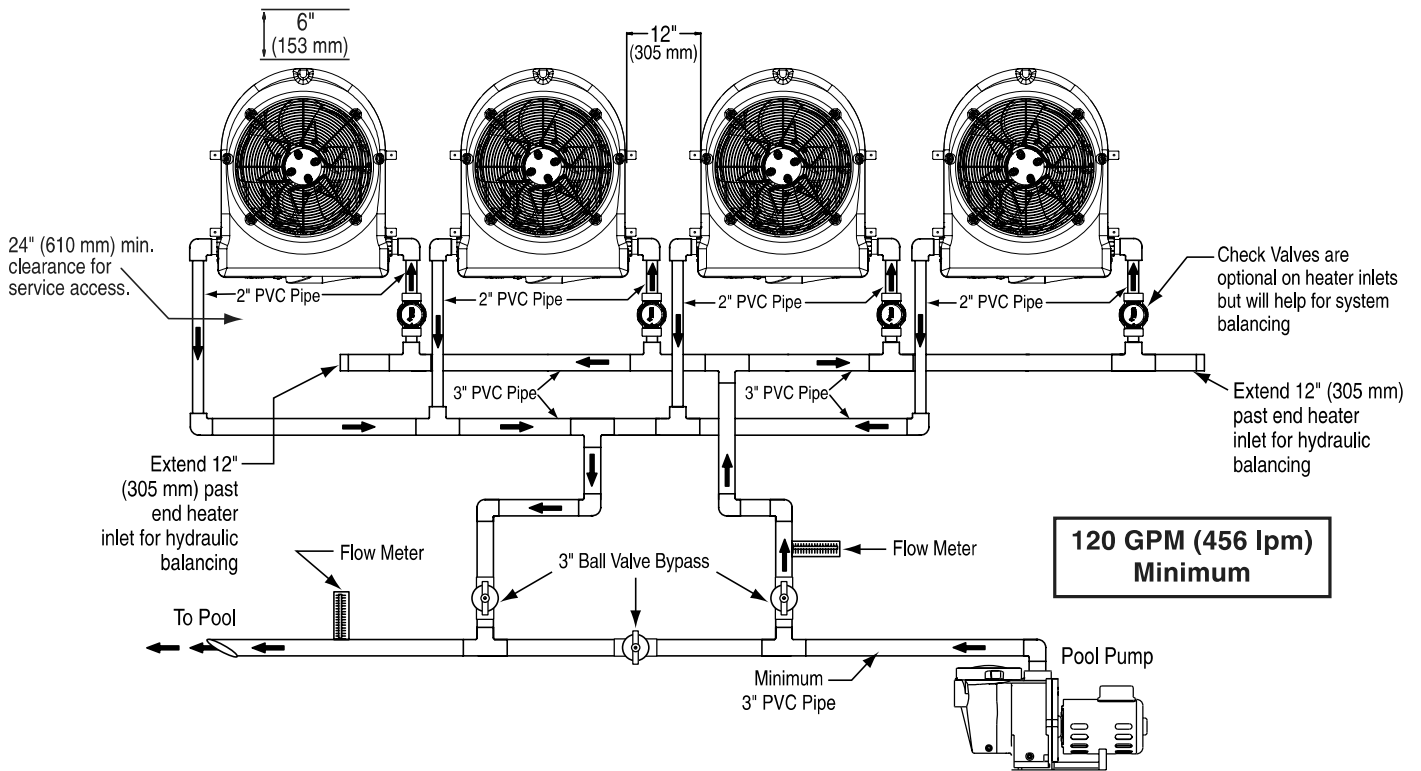

Four Heat Pump Plumbing Layout

Electrical Connections and Wiring

⚠ WARNING

RISK OF ELECTRICAL SHOCK OR ELECTROCUTION.



This heat pump contains wiring that carries high voltage. Contact with these wires could result in death or serious injury to pool or spa users, installers, or others due to electrical shock, and may also cause damage to property. Always disconnect power circuit before connecting the heat pump.

⚠ CAUTION

Label all wires prior to disconnection when servicing controls. Wiring errors can cause improper and dangerous operation. Verify proper operation after servicing.

General Information

Wiring connections must be made exactly as shown in the wiring diagram found on the inside of the heat pump access panel; see the wiring diagrams on pages 10-11.

The UltraTemp® Heat Pump must include a definite means of grounding and bonding. There is a ground lug inside the heat pump electrical compartment and a bonding lug on the left side of the heat pump.

Bonding

The National Electrical Code and most other codes require that all metallic components of a pool structure, including reinforcing steel, metal fittings, and above ground equipment be bonded together with a solid copper conductor not smaller than 8 AWG. For Canada, a 6 AWG or larger solid copper bonding conductor is required. The heat pump, along with pumps and other pool equipment must be connected to this bonding grid. A bonding lug is provided on the left side of the heat pump to ensure this requirement is met.

⚠ CAUTION

This heater must be connected to a bonding grid with a solid copper wire not smaller in diameter than 8 ga. For Canadian installations a solid copper wire not smaller in diameter than 6 ga should be used.

Main Power

Electrical wiring to the heat pump must be in accordance with the latest edition of the National Electric Code (NEC), ANSI/National Fire Protection Association (NFPA) 70 in the United States, and in Canada, the Canadian Electrical Code (CEC) C22.1, unless local code requirements indicate otherwise. All wiring must be done by a certified or qualified electrician.

The following is the procedure to wire the heat pump to the electrical source:

Be sure the power to the circuit for the heat pump is turned off.

1. Remove the front left panel of the heat pump cabinet, (you do not need to remove the star-head screw at the top left corner).
2. Remove the service panel to the heat pump electrical compartment. (Front left corner of unit)
3. Electrical supply lines must be run through watertight conduit. Run the wires and conduit from the power source and connect them to the conduit connection on the left side of the heat pump.
4. Connect the power leads to the bottom terminals on the main compressor contactor as shown in the wiring diagram.
5. Verify that all other contactor wires are secure, they may have loosened during shipment.
6. Connect the ground wire to the ground lug provided on the bottom of the electrical compartment.
7. Replace the service panel and reinstall screws to hold it in place.
8. Replace the front left panel.
9. Connect a copper bonding wire (8 AWG) (6 AWG in Canada) to the bonding lug on the left side of the heat pump.

Wiring Diagram – (Single Phase – 50Hz/60Hz)

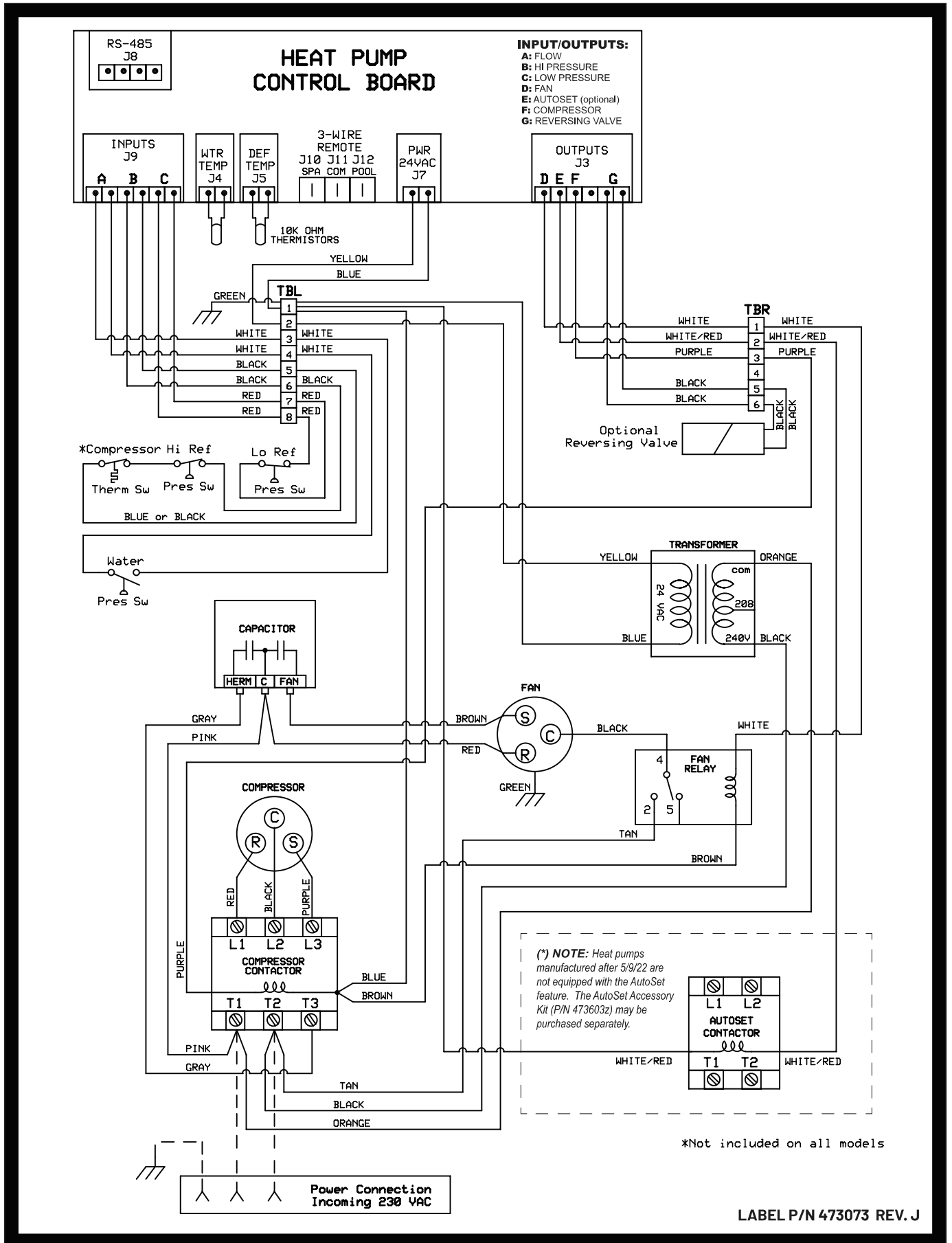

Wiring Diagram – (Three Phase – 60Hz)

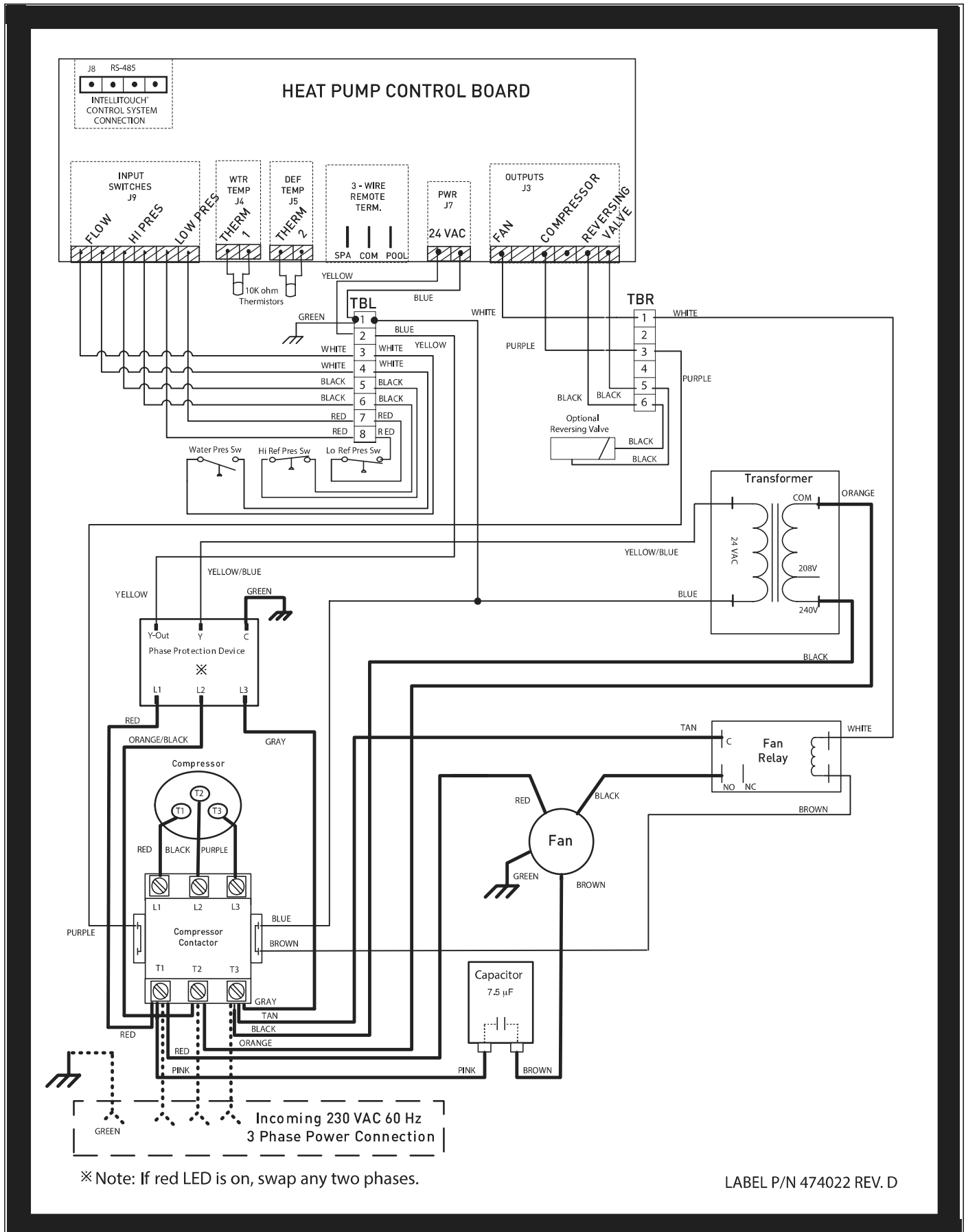

CONNECTING TO AN AUTOMATION SYSTEM

Remote Operation

The UltraTemp® Heat Pump may be connected to an automation system via the remote spade terminals on the back of the control board (see page 12-13) or via the RS-485 communication connector on the back of the control board (see page 14-15). Refer to the IntelliTouch® or EasyTouch® Control System installation and user's guide for more information.

Note: Remote connection via the RS-485 connector is only available on IntelliTouch and EasyTouch software version 1.11 or higher. All other automation packages must connect via the ¼ in. "Spade" terminals (spade terminals not supplied).

Relay Remote Controls

Electrical wiring must be in accordance with the latest edition of the NEC (NFPA 70) in the United States and CEC (CSA 22.1) in Canada, unless local code requirements indicate otherwise.

To connect remote control equipment to the heat pump, perform the following steps:

1. Turn off the power to both the remote pool/spa control system and the heat pump.
2. Remove the front left panel of the heat pump cabinet, (you do not need to remove the star-head screw at the top left corner).
3. Remove the electrical service panel to the heat pump. Remove the 4 bezel retaining screws from above the electrical compartment and rotate the bezel downward. This will allow you to access the Remote terminals on the back of the heat pump control board for the remote control installation.

4. Run the wires from the pool/spa remote control system into the upper electrical compartment.
5. Connect the wiring from the pool/spa remote control system to the heat pump remote control terminals using ¼ in. "Spade" connectors as shown in the image below.
6. Rotate the bezel back upwards into position and reinstall the 4 retaining screws.
7. Replace the electrical service panel.
8. Replace the front left panel.
9. Restore power to the heat pump and the pool/spa remote control system.
10. Press the MENU SELECT button repeatedly to scroll to the Remote Mode screen. Toggle the selection by pressing one of the arrows until the screen displays "Relay".
11. Turn on the heat pump.

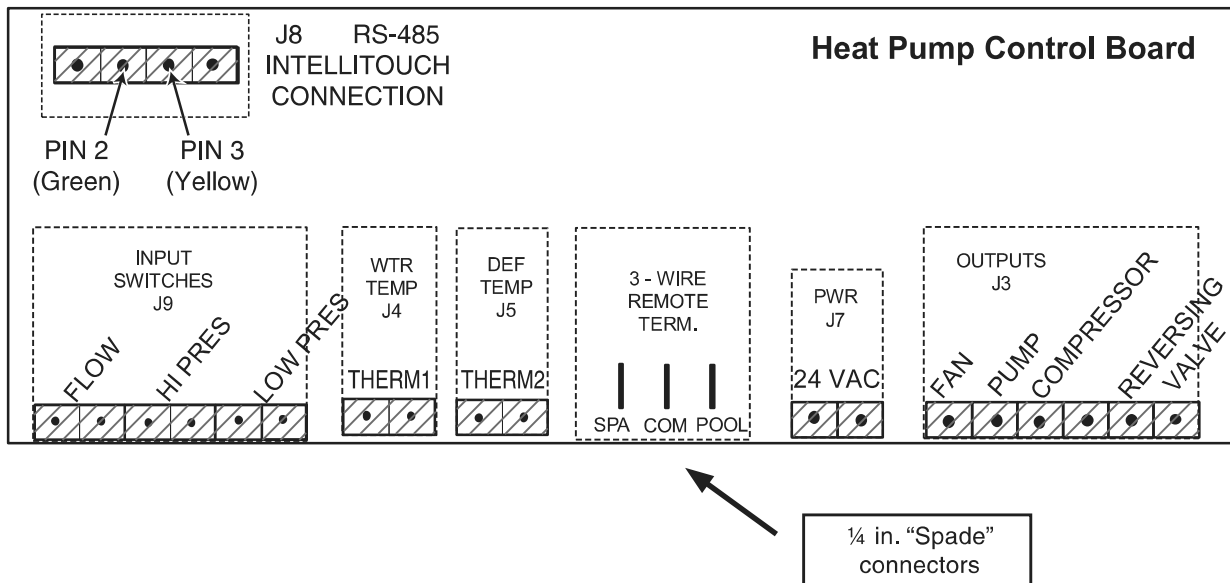

Connecting the Heat Pump to the IntelliTouch® or EasyTouch® Control System Load Center via the Heat Pump Spade Terminals

To connect the UltraTemp® Heat Pump cable to the Personality Board in the IntelliTouch or EasyTouch Load Center:

1. Turn off the main system power before making any connections.
2. Unlatch the front door spring latches, and open the front door of the IntelliTouch or EasyTouch Load Center.
3. Loosen the two retaining screws from the top of the control panel and lower the control panel down to access the Personality Board.
4. Run a UL approved conductor cable from the heat pump to the Load Center.
5. Route the cable up through the low voltage raceway located on the left of the Load Center to the Personality Board, see image below.
6. Insert the UltraTemp cable plug onto the gas heater terminal connector, located on the left side of the Personality Board.

7. If the heat pump is used in conjunction with a gas heater, use a 520403 Dual Heater Relay Kit. Plug the heat pump relay connector onto the SOLAR Terminal on the top center of the Personality Board. Follow the Dual Heater Relay Kit instructions for further set-up details. Be sure to install solar temperature sensor as per instructions.
8. Lift the control panel up into position and secure with the two screws.
9. Connect the cable from the IntelliTouch or EasyTouch Load Center to the heat pump remote control terminals using ¼ in. "Spade" connectors, Refer to previous page for wiring instructions.

Note: Solar temperature sensor could be left loose in load center. The automation system does not use the temperature reading but just looks for resistance.

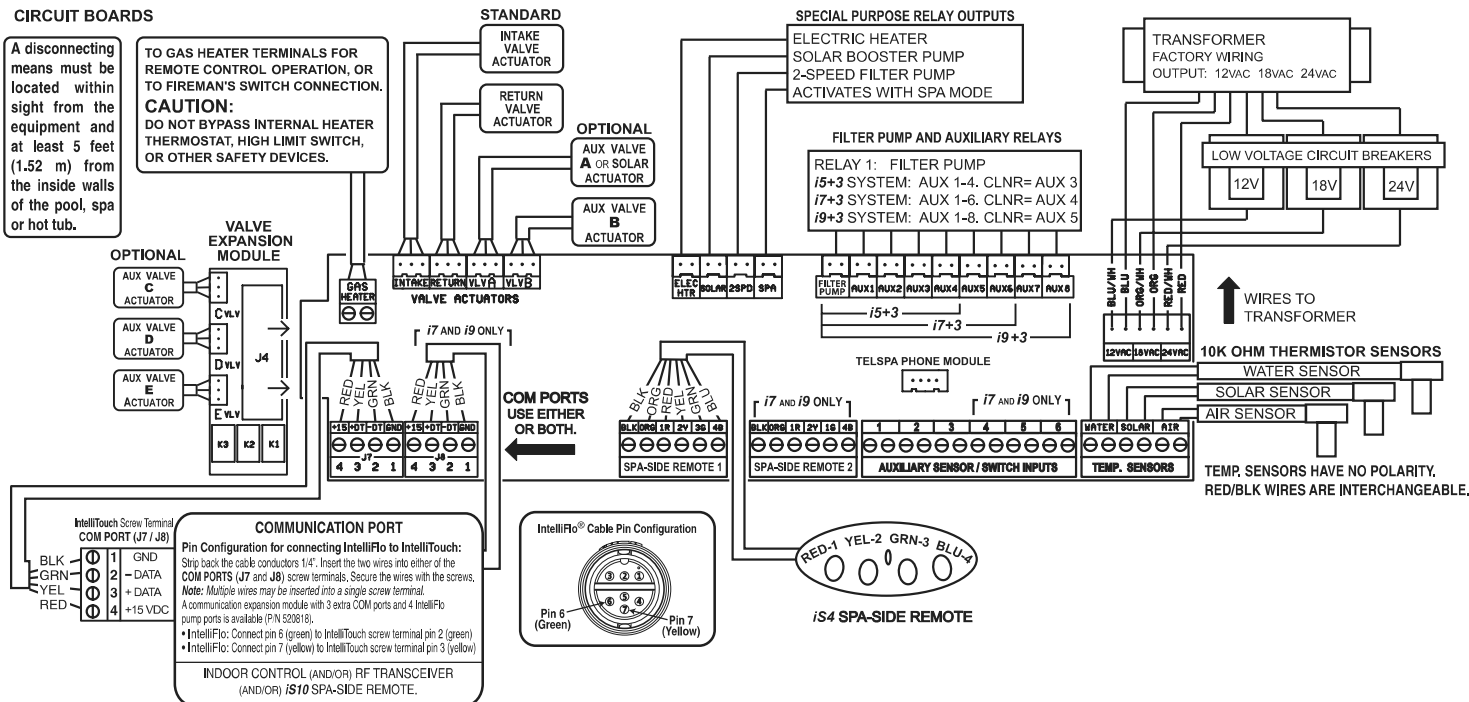

IntelliTouch/EasyTouch Load Center Wiring Diagram

Connecting the Heat Pump to the IntelliTouch® or EasyTouch® Control System Load Center via the RS-485 Connector

CAUTION Switch the main power off to the IntelliTouch® or EasyTouch® load center before servicing.

The UltraTemp® Heat Pump can be controlled by an IntelliTouch or EasyTouch system via the RS-485 communication cable. In this configuration, IntelliTouch or EasyTouch overrides preset Temperature Set points on the heat pump.

The transfer of this data takes several seconds and causes a delay from when the command is given from the IntelliTouch or EasyTouch indoor control panel until the heat pump physically responds. This happens automatically but may take 1-2 minutes to complete.

Note: Heat pump control board set points will be shown as “N/A” and will be functionality disabled. For more information, refer to the IntelliTouch User’s Guide (P/N 520102) or the EasyTouch User’s Guide (P/N 520584) or the EasyTouch Wireless System User’s Guide (P/N 520688).

Connection from heat pump board to the IntelliTouch or EasyTouch system is via the optional four-wire cable (P/N 520199).

To connect the heat pump board cable to the IntelliTouch or EasyTouch load center:

1. Unlatch the IntelliTouch or EasyTouch load center front door spring latches, and open the front door.
2. Remove the cover-panel screws securing the high voltage cover-panel, and remove it from the enclosure.
3. Loosen the two control panel access screws and fold down the outdoor control panel.
4. Insert the four-wire cable into plastic grommet on the bottom of the enclosure and route the wire up through the low voltage raceway to the Personality board.
5. Strip back the cable conductors $\frac{1}{4}$ in. Insert the wires into either of the COM PORTS (J7 and J8) screw terminals located on the left side of the Personality board. Secure the wires with the screws. For wiring details, refer to the pin configuration as shown on page 15.

Note: Multiple wires may be inserted into single screw terminal.

6. Close the IntelliTouch control panel and secure it with the two access screws.
7. Install the high voltage panel cover and secure it with the two retaining screws.
8. Close the load center front door and secure with the two latches.
9. Switch power on to the IntelliTouch load center.

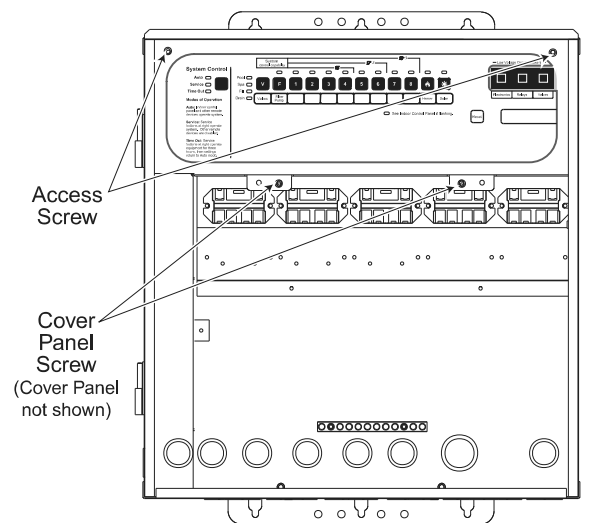
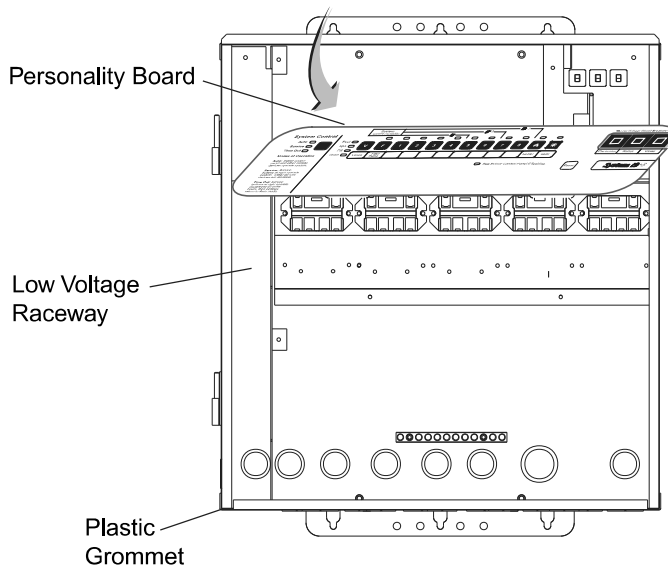

IntelliTouch Load Center

Pin Configuration for the Heat Pump Control Board to IntelliTouch® Control System

1. Heat Pump Control Board: Connect pin 2 (green) to IntelliTouch screw terminal pin 2 (green).
2. Heat Pump Control Board: Connect pin 3 (yellow) to IntelliTouch screw terminal pin 3 (yellow)

IMPORTANT — Do **NOT** use pin 1 (black) or pin 4 (red) on the AutoSet board or the IntelliTouch mother board.

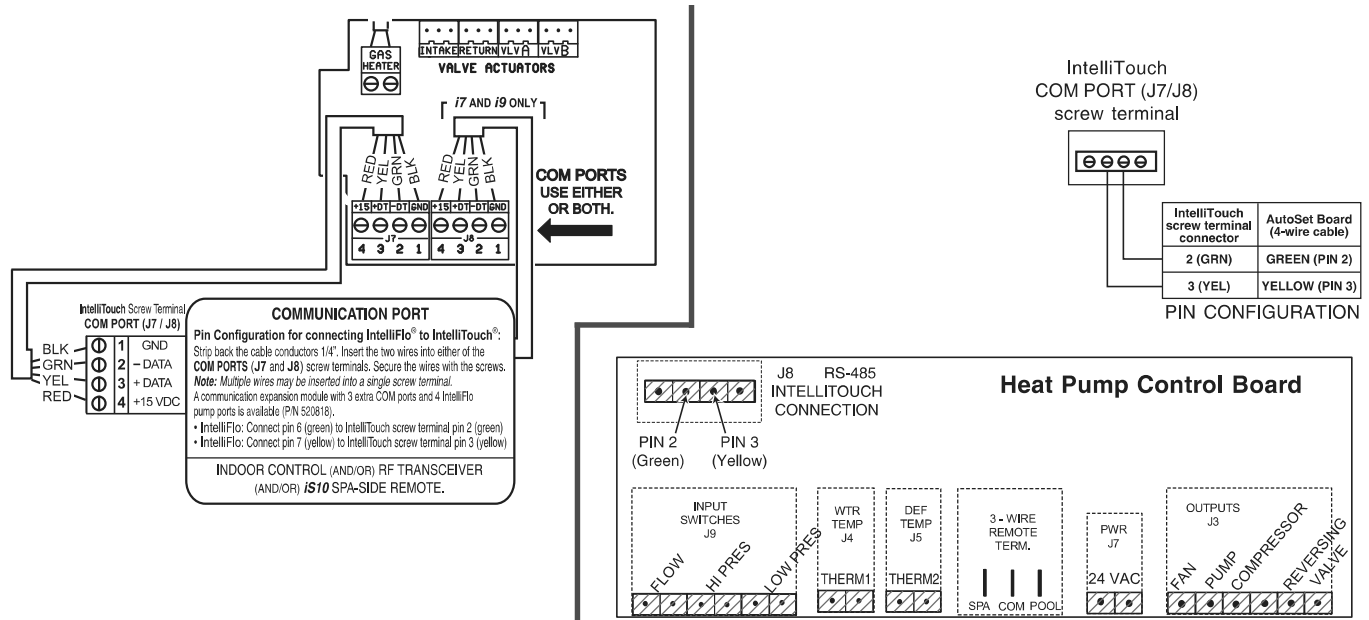

Connecting the IntelliTouch or EasyTouch to Heat Pump

1. Turn off the power to both the remote pool/spa control system and the UltraTemp® Heat Pump.
2. Remove the front left panel of the heat pump cabinet, (you do not need to remove the star-head screw at the top left corner).
3. Remove the electrical service panel to the heat pump. Remove the 4 bezel retaining screws from above the electrical compartment and rotate the bezel downward. This will allow you to access the Remote terminals on the back of the heat pump control board for the remote control installation.
4. Run the wires from the pool/spa remote control system into the upper electrical compartment.
5. Connect the wiring from the IntelliTouch Personality Board COM PORT to the RS-485 IntelliTouch connection (J8) on the heat pump control Board. Connect the green wire to J8 pin 2 and yellow wire to J8 pin 3. Do NOT use pin 1 (red) or pin 4 (black) wires. The connections are shown in the image above.
6. Rotate the bezel back upwards into position and reinstall the 4 retaining screws.
7. Replace the electrical service panel.
8. Replace the front left panel.
9. Restore power to the heat pump and the pool/spa remote control system.
10. Press the MENU SELECT button to scroll to the Remote Mode screen. Toggle the selection by pressing one of the arrows until the screen displays "RS-485."
11. Once the heat pump has been correctly configured, a "heartbeat" indicator will appear on the main screen each time a message is received from the automation system.

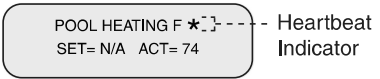

Note: If the system is put into Service Mode at the automation control panel the heat pump will neither heat nor cool, although it will remain powered on.

OPERATING THE HEAT PUMP

CAUTION

Do not use this heat pump if any part has been under water. Immediately call a qualified service technician to inspect the heater and replace any part of the control system which has been under water. Keep all objects off the top of the heat pump. Blocking air flow could damage the unit and may void the warranty.

ATTENTION - INITIAL START UP PRECAUTIONS

After the water pressure switch is activated there is a one minute temperature sensing delay then if there is a call for heat or cool the fan will turn on and there will be an additional 5 minute delay for the compressor to start. Be sure that there is water in the pool and that the surface level is above the skimmer or other inlets of the pool's filter system.

The pool pump must be on and water flowing through the heat pump for it to operate.

With any new pool or spa installation, operate the filter pump with the heat pump off long enough to completely clean the water. This will remove any installation residue from the water. Clean the filter at the end of this operation before starting the heat pump. When raising the temperature of a cold pool, program the time clock to run the pump continuously. This lets the filter system and heat pump operate continuously until the water reaches the temperature setting on the temperature control. When that happens, the heat pump will automatically shut off, but the filter pump will keep running.

Swimming Pool Energy Saving Tips

It is important to note that an UltraTemp® Heat Pump will not heat a pool as fast as a large gas or electric pool heater. If the pool water is allowed to cool significantly, it may take several days to return to the desired swimming temperature.

For weekend use, it is more economical to maintain the water temperature at or near the desired temperature. For extended non-use, turn the heat pump completely off or decrease the temperature setting of the control several degrees to minimize energy consumption.

Pentair offers the following recommendations to help conserve energy and minimize the cost of operating your heat pump without sacrificing performance.

1. The American Red Cross recommends a maximum water temperature of 78°F [25°C]. Use an accurate pool thermometer. A difference of 4°F. [2°C] , between 78°F and 82°F [26°C and 28°C], will significantly increase energy consumption.
2. Carefully monitor the water temperature of your pool in the summertime. You can reduce heat pump usage due to warmer air temperatures.
3. During the winter or when on vacation for longer than a week, turn off the heat pump.
4. Find the proper setting on the heat pump temperature control and use the Keypad Lock function to discourage further adjustments.
5. Where possible, shelter the pool from prevailing winds with well-trimmed hedges or other landscaping, cabanas, or fencing.
6. Pentair recommends the use of a pool cover. Besides providing a valuable safety feature, a pool cover will reduce heat loss, conserve chemicals, and reduce the load on filter systems.

Heat Pump Control Panel Overview

1. **ON/OFF** button – Turns the heat pump ON and OFF.
2. **MENU SELECT** button – Displays Operator Menu Screens; also used to scroll through these menus.
3. **POOL/SPA** button – If pressed once, the current heat, cool or auto mode will be displayed along with the active set point, pool or spa.
Pressing again will toggle between the pool or spa set point screens. The operator can also toggle between the pool and spa set point by using the UP and DOWN arrows.
4. **UP and DOWN Arrow** buttons – The UP and DOWN arrows will raise or lower the temperature set point if pressed while the run screen is displayed. They are also used to scroll through the various parameter values on the Operator Menus and Service Menu screens.
5. **LCD SCREEN** – Displays water temperature, set point temperature and heat pump parameters.
6. **ON Light** – Shows the heat pump is on.
7. **SERVICE Light** – Lit if alarm condition exists.

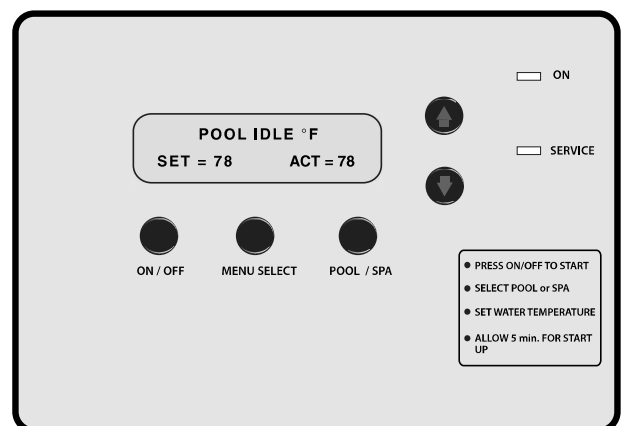

Heat Pump Control Panel

Operator Menu Tree Guide (Press MENU SELECT Button)

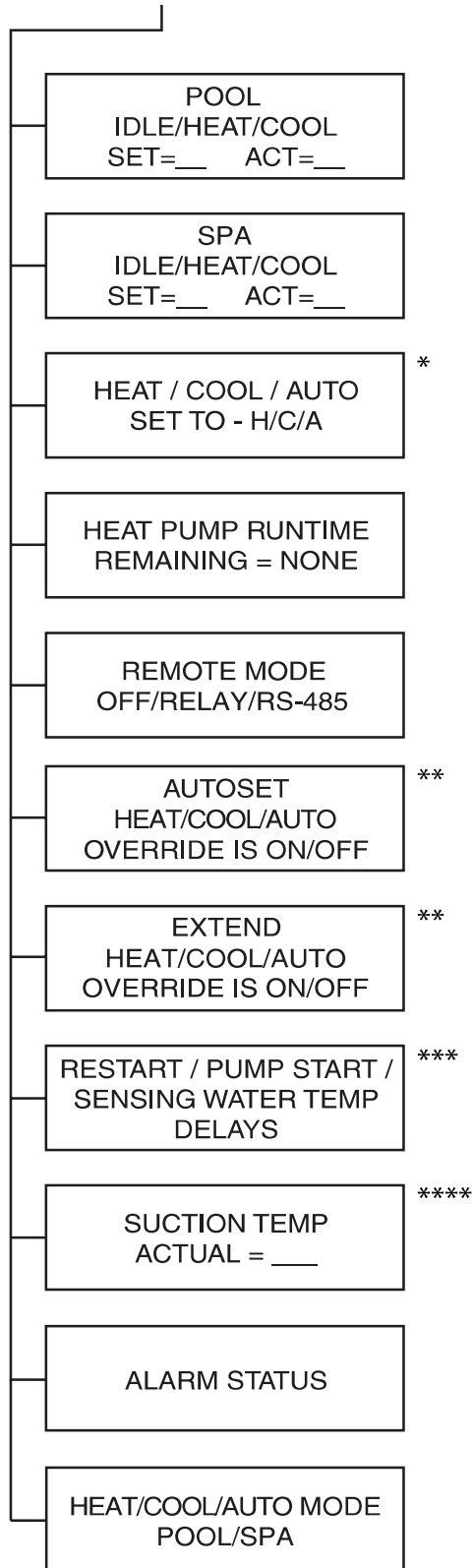

* Menu appears only if Heat and Cool mode is enabled at the factory.

** Menu appears only if AutoSet or Extend is enabled in the Service menu.

*** Menu appears only if a delay is active.

**** Menu appears only if Defrost is enabled in the Service menu.

Navigating the Operator Menu Screens

Press the MENU SELECT button to view each screen. While in the menu screens, if no activity is detected after 15 seconds, the main screen is displayed.

1. Pool and Spa Run Screens

Displays whether the heat pump is idle, heating or cooling and if the Pool or Spa set point is active. Displays the water temperature set point and the actual measured water temperature.

* 2. Heat or Cool Mode Selection Screen

This screen is only shown on Heat-and-Cool heat pumps. This screen allows the operator to switch the heat pump between Heat-only, Cool-only and Auto Heat/Cool modes.

3. Heat Pump Timer Screen

This feature is an adjustable timer to allow the heat pump to run (green light ON) for a predetermined amount of time and then turn OFF (green light OFF).

4. Remote Mode Screen

Allows the operator to select the Remote mode, Off, Relay or RS-485 (serial). In RS-485 Remote mode, the heat pump is controlled by an automation controller. The local Pool and Spa set points are not active (displayed as "N/A") in this mode.

** 5. AutoSet On/Off Screen

This screen is only shown if the AutoSet mode is enabled in the Service Menu Tree; it allows the operator to turn the AutoSet mode On and Off. AutoSet mode energizes a contactor for one cycle and starts a remote filter pump which allows the heat pump to heat or cool the water as necessary.

** 6. Extend On/Off Screen

This screen is only shown if the Extend mode is enabled in the Service Menu Tree; it allows the operator to turn the Extend mode On and Off. Extend mode energizes a contactor for one cycle and starts a remote filter pump which allows the heat pump to heat or cool the water as necessary.

*** 7. Time Delay Screen

If the heat pump is waiting on any restart, pump start, or sensing water temperature delays, this screen shows how much delay time is left.

**** 8. Suction Temperature Screen

Shows the suction line temperature of the refrigerant. This screen appears if the Defrost is enabled.

9. Alarm Screen

Shows if an alarm condition is present. If no alarms are present the screen will display ALARM STATUS NONE. The control board has the ability to store a 30 Alarm history of previous alarms that have occurred. At the alarm status screen, press the DOWN arrow. The first alarm will be the most recent alarm that has occurred. Successive presses (up to 30) of the DOWN arrow will display the alarm history in the order of occurrence. The operator can scroll back up using the UP button. There is an option to erase the history.

10. Operation Mode Screen

Displays whether the heat pump is in Heat, Cool or Auto mode. It also displays whether the Pool or Spa set point is active. The active set point can be switched between Pool and Spa by using the UP and DOWN arrows.

Using the Control Panel

Starting and Stopping the Heat Pump

The UltraTemp® Heat Pump is started and stopped with the ON/OFF button.

1. Starting - With power supplied to the heat pump, press the ON/OFF button to start the heat pump. The ON light should be lit.
2. Stopping - Press the ON/OFF button to stop the heat pump; the ON light will turn off. The screen shown below will be displayed temporarily.

PENTAIR AQUATICS
HEAT PUMP OFF

Changing the Set Point (Temperature)

The control board has two independently adjustable temperature set points. One is for the pool temperature control and the other is for the spa temperature control. The active mode of operation (Pool or Spa) is defined as the “active” set point.

1. Press the MENU SELECT button repeatedly until the associated run screen is displayed. Press the UP or DOWN arrows to adjust the pool or spa temperature set point.
SET= ___ - Set point
ACT= ___ - Actual measured water temperature
2. The screen automatically returns to the active run screen after 15 seconds of keypad inactivity.

POOL
IDLE/HEAT/COOL
SET=___ ACT=___

Heat, Cool, and Auto Modes

Certain models have the ability to both heat and cool. These heat pumps can be setup to operate in any one of three modes (Heat Only, Cool Only, or Auto Heat and Cool).

In Auto mode, the heat pump automatically switches between heat and cool based on whether the water temperature is below or above the active set point.

1. If the cooling option is available, press the MENU SELECT button repeatedly until the Heat/Cool/Auto screen displays.
2. Press the UP or DOWN arrows to scroll through the heat, cool and auto options. The last option shown on the display becomes active.

Heat Pump Timer

This feature is an adjustable timer to allow the heat pump to run for a predetermined amount of time (green light ON) and then turn OFF (green light OFF).

During the selected time frame, the green light is ON and the heat pump functions in the normal mode of operation. When time expires the green light turns OFF and the heat pump turns off. Countdown time is in hours and minutes.

To activate the Heat Pump Timer:

1. Press MENU SELECT repeatedly until the Heat Pump Timer screen is displayed.
2. Press UP or DOWN arrows to set the amount of time (range of 10 minutes to 99 hours). Timer adjusts in increments of 10 minutes.

If the heat pump is not already on, setting the timer will activate and start the heat pump.

3. The user can also change the time while it is active using the arrow buttons, but only if Remote mode is OFF. Setting Remote Mode to RELAY or RS-485 disables the Heat Pump Timer at the control panel.
4. Any RS-485 communication received will reset the timer to zero. The RS-485 overrides the Heat Pump Timer operation.
5. The timer can be disabled by pressing the DOWN arrow and POOL/SPA buttons at the same time, or by pressing the ON/OFF button.

HEAT PUMP RUNTIME
REMAINING = NONE

Relay Remote

In Relay Remote operation, the heat pump is started and stopped by remote relays which are connected to the remote POOL, COMMON and SPA quick connect terminals on the back of the control board.

When conductivity is provided between the POOL and COMMON terminals or the SPA and COMMON terminals, the heat pump will start. All other features and functions (except for the Heat Pump Timer) are still active. The heat pump will not heat above 104°F or cool below 45°F (40°C - 7.2°C).

To activate the Relay Remote Mode:

1. Press MENU SELECT repeatedly until the Remote Mode screen is displayed. Once displayed, press the UP or DOWN arrows to select RELAY. The last option shown on the display becomes active.
2. Press MENU SELECT repeatedly until the Heat/Cool/Auto Mode Screen is displayed. Press the UP or DOWN arrows to toggle between HEAT, COOL and AUTO. Select HEAT or COOL. AUTO is not a valid selection while the heat pump is in Relay Remote mode operation.

REMOTE MODE
RELAY

RS-485 Remote (Serial Cable)

See IntelliTouch® or EasyTouch® Control System Installation User's Guides for additional setup instructions.

In RS-485 Remote mode, the heat pump is started and stopped via a serial RS-485 communications link with a Pentair automation controller. This means the remote automation controls override the heat pump's local set point. The high and low temperature faults are still active; the heat pump will not heat above 104°F or cool below 45°F (40°C - 7.2°C).

Note: If the system is put into Service Mode at the automation control panel the heat pump will neither heat nor cool, although it will remain powered on.

To activate the RS-485 Remote mode:

1. Press MENU SELECT repeatedly until the Remote mode screen is displayed. Once displayed, press the UP or DOWN arrows to select RS-485.

REMOTE MODE
RS-485

To use the RS-485 Remote mode, the Intell Address screen from the Service Menu Tree must be assigned to the proper address. One (1) is the most commonly used.

The Intell Address must match the address assigned to the heat pump. The heat pump address can be edited from the Service Menu as described below:

1. Press the UP and DOWN arrows simultaneously. The Language Selection screen should be displayed.

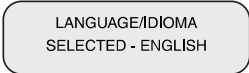

2. Press the MENU SELECT button repeatedly until the Intell Address screen displays. Press the UP or DOWN arrows to select the address used in the automation controller. The last address shown on the display will become active.

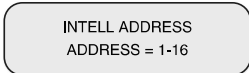

3. Once the heat pump has been correctly configured, a "heartbeat" indicator will appear on the main screen each time a message is received from the automation system.

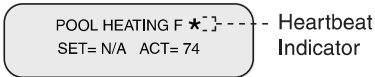

AutoSet

Heat pumps manufactured after 5/9/22 are not equipped with the AutoSet feature. The AutoSet Accessory Kit (P/N 473603z) may be purchased separately.

The AutoSet feature periodically energizes a contactor connected to a filter pump. This allows the heat pump to start and stop the filter pump independent of the time clock, allowing the heat pump to circulate water and sense water temperature. Enable this feature any time the filter pump is off.

When the temperature is not as desired, the heat pump will start and run until the water reaches the desired temperature. The filter pump and heat pump will then stop.

AutoSet allows you to set the time interval between the end of the circulation cycle and when the heat pump reactivates the filter pump to sense the water temperature.

To enable the AutoSet feature:

1. Ensure the filtration pump is wired in parallel with a mechanical time clock, using the auxiliary relay supplied in the high voltage power panel of the heat pump.
2. Press the MENU SELECT button repeatedly until the AutoSet screen is displayed.
3. Press the UP or DOWN arrows to toggle between ON and OFF.
4. Set the interval (1-4 hours) from the Pump Start Time menu within the Service Menu tree to control when the heat pump sends a signal to check the water temperature.

If you (1) select a Pump Start Time interval of four hours, (2) the AutoSet feature is enabled and (3) AutoSet Override is ON, this is the sequence of events that will happen:

1. The heat pump displays a countdown window after the filter pump shuts off.

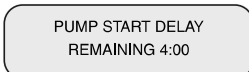

2. After 4 hours, the heat pump will activate and start the filter pump to sense the water temperature.
3. If the water temperature has fallen below the programmed Set Point, the heat pump will activate and begin heating the pool. If the water temperature is above the Set Point, the heat pump and filter pump will shut off.
4. When the water circulation pump shuts off, the heat pump will reset, begin the countdown interval and display 'Pump Start Delay'.
5. The heat pump will continue this cycle each time the filter pump is shut off.
6. Once the time clock restarts the filter pump, the heat pump will stop the AutoSet feature and resume normal operation.

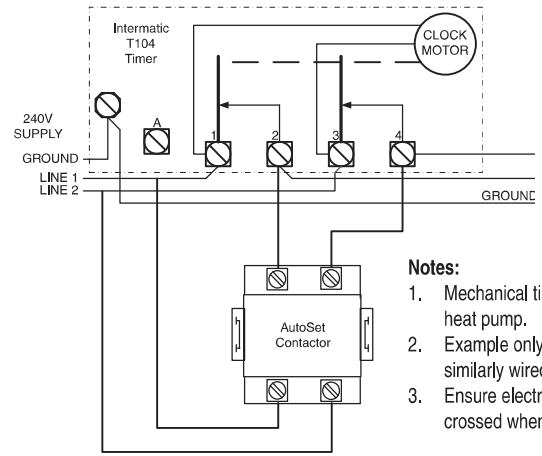

- Notes:**
1. Mechanical timer not provided with heat pump.
 2. Example only; other timers will be similarly wired.
 3. Ensure electrical power lines are not crossed when making connections.

AutoSet Contactor to Mechanical Timer Wiring

Extend

The Extend feature can energize a contactor connected to a filter pump. This allows the heat pump to start and stop the filter pump independent of the time clock, allowing the heat pump to circulate water and sense water temperature.

When the temperature is not as desired, the heat pump will start and run until the water reaches the desired temperature. The filter pump and heat pump will then stop.

To enable the Extend feature:

1. Ensure the filtration pump is wired in parallel with the mechanical time clock and the auxiliary relay installed on the high voltage panel of the heat pump.
2. Press the MENU SELECT button repeatedly until the Extend screen is displayed.
3. Press the UP and DOWN arrows to toggle between ON and OFF.

If you have the Extend feature enabled and the Extend Override set to ON, this is the sequence of events that will happen:

1. When the filter pump shuts off, the heat pump immediately senses water temperature.
2. If the water temperature has fallen below the programmed Set Point, the heat pump will start the filter pump and begin heating the pool. If the water temperature is above the Set Point the heat pump and filter pump will shut off.
3. Once the time clock restarts the filter pump, the heat pump will stop the Extend feature and resume normal operation.

Timers And Delays

1. Water Sensing Timer

One (1) minute timer to allow water from the pool to reach the UltraTemp® Heat Pump before acquiring temperature. This timer initiates when water first begins to run from stopped or low water flow conditions or when the heat pump is turned ON. Countdown time is in Minutes and Seconds.

SENSING WATER TEMP
REMAINING = 1:00

2. Restart Delay Timer

Five (5) minute timer is a protection feature for the heat pump's compressor. This extends the life of the compressor by not allowing it to cycle on and off rapidly, (i.e. adjusting set point up and down around actual temperature). Countdown time is in minutes and seconds.

RESTART DELAY
REMAINING = 5:00

3. Defrost Delay Timer

Fifteen (15) minute timer where the Heat pump is in Defrost operation. Countdown time is in minutes and seconds. Refer to page 22 for more details on the defrost cycle.

DEFROST DELAY
REMAINING = 15:00

4. Pump Start Delay

One to four (1-4) hour timer used in conjunction with the AutoSet feature. Counts down the time until the control board will energize the internal contactor in the heat pump. Countdown time is in hours and minutes. See AutoSet section for more details.

PUMP START DELAY
REMAINING 4:00

5. Heat Pump Runtime Timer

This feature is an adjustable timer to allow the heat pump to run (green light ON) for a predetermined amount of time and then turn OFF (green light OFF). During the selected time frame the green light is ON and the heat pump will function in the normal mode of operation and/or the operator can change set points, functions, etc. The heat pump's green light will turn OFF and the heat pump will stay OFF when time expires.

HEAT PUMP RUNTIME
REMAINING = NONE

Control Panel Alarm Messages

HIGH WATER TEMP	Water temperature is above 107°F [41.7°C].
LOW WATER TEMP	Water temperature is below 40°F [4.4°C].
LOW WATER FLOW	The pressure switch sensing water flow is open.
REMOTE POOL/SPA	Pool and Spa relay remote inputs are simultaneously energized.
WATER THERM SHORT	Water temperature thermistor circuit shorted.
WATER THERM OPEN	Water temperature thermistor circuit open.
SUCTION TH SHORT	Defrost thermistor circuit shorted
SUCTION TH OPEN	Defrost thermistor circuit open.
LOW AMBIENT TEMP	Air temperature is too low for heat pump operation.
BROWNOUT	The 24 VAC supply voltage to the control board is low.
HIGH REFRIG	Refrigerant high pressure switch is open.
LOW REFRIG	Refrigerant low pressure switch is open.
SERIAL COMM LOST	Control board has not received a message from the automation controller for two (2) minutes.
FIVE ALARMS	Indicates that five (5) faults have occurred in one (1) hour. This fault will automatically reset in one (1) hour or can be manually reset by pressing the ON/OFF button.

Service Menu Tree Guide

(Press UP and DOWN Arrows Simultaneously)

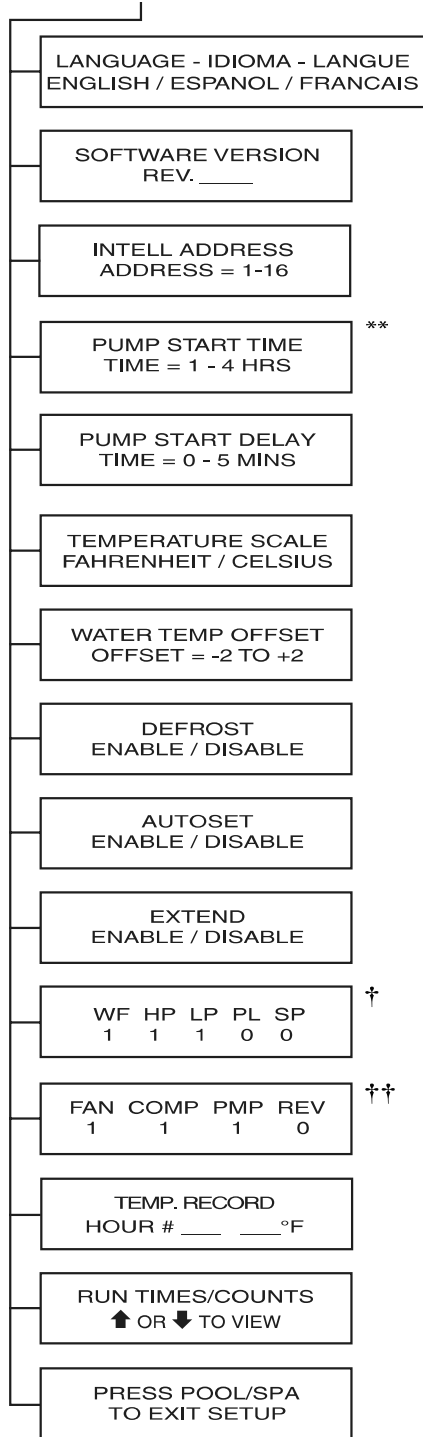

** Menu appears only if AutoSet or Extend is enabled in the Service menu.

† **INPUT STATUS**

- WF = WATER FLOW SWITCH
- HP = HIGH REFRIGERANT PRESSURE SWITCH
- LP - LOW REFRIGERANT PRESSURE SWITCH
- PL - POOL REMOTE
- SP - SPA REMOTE

†† **OUTPUT STATUS**

- FAN - FAN
 - COMP - COMPRESSOR
 - PMP - FILTER PUMP
 - REV - REVERSING VALVE
- The number one (1) is displayed when the associated input/output is ON and zero (0) is displayed when input/output is OFF.

Navigating the Service Menu Screens

Press the UP and DOWN arrows simultaneously. If no activity is detected after 15 seconds, the display will return to the main screen.

1. Language Selection

Displays the language selected. Select either English, Spanish or French using the UP and DOWN arrows.

2. Software Revision

Displays the software revision level loaded on the control board.

3. Intell Address

Heat Pump RS-485 Communications Address which must match the address used in the IntelliTouch or EasyTouch automation controller being communicated with. Adjustable from 1 to 16 using the UP and DOWN arrows.

** **4. Pump Start Time**

This displays the period at which the heat pump will close the AutoSet contactor to start the filter pump. Adjustable from 1 to 4 hours using the UP and DOWN arrows.

5. Pump Start Delay

Displays the time period between heat pump start cycles. Adjustable from 0 to 5 minutes using the UP and Down arrows.

6. Temperature Scale

Determines if the water temperature actual reading and set point is displayed in degrees Fahrenheit or Celsius. Adjusted between Fahrenheit and Celsius using the UP and DOWN arrows.

7. Temp Offset

Adjusts the measured water temperature up or down to allow the operator to match the heat pump's displayed temperature to a remote temperature monitoring device. The offset can be varied from -2 to +2 using the UP and DOWN arrows.

8. Defrost Screen

Allows the user to Enable/Disable Defrost feature.

9. AutoSet Screen

Allows the user to Enable/Disable AutoSet feature.

10. Extend Screen

Allows the user to Enable/Disable Extend feature.

† **11. Input Screen and Output Screen**

The Input and Output screens are diagnostic displays which show the status of the input sensors and output devices. The number one (1) is displayed when the associated input/output is on and zero (0) is displayed when the associated input/output is off.

12. Temperature Log and Run Time Counters

These screens display a list of compressor, fan and valve run times, and a history of measured water temperatures. This information is provided so the user can easily track performance and troubleshoot issues.

13. Exit Set Up

Pressing the POOL/SPA button while this screen is displayed returns the display to the Pool or Spa Run Screen as appropriate.

Temperature Scale - C° or F°

The control board can display temperatures in either degrees Fahrenheit or Celsius. The temperature scale in use can be changed from the Service Menu tree as described below:

1. Press the UP and DOWN arrows simultaneously. The Language Selection screen should be displayed.
2. Then press the MENU SELECT button repeatedly until the Temperature Scale screen is displayed.
3. Press the UP or DOWN arrows to toggle between the Fahrenheit and Celsius options. The last option shown on the display will become active.

Water Temperature Offset

The control board provides the ability to increase or decrease the displayed water temperature by 2 degrees.

To change the temperature offset:

1. Press the UP and DOWN arrows simultaneously.
2. Press the MENU SELECT button repeatedly until the Temperature Offset screen is displayed.
3. Press the UP or DOWN arrows to select the desired offset. The last number shown on the display will become active.

TEMP OFFSET
OFFSET = -2 TO +2

Defrost Cycle

The UltraTemp® Heat Pump may enter a defrost cycle if air temperatures are around 50°F (10°C). To enter a defrost cycle the Defrost feature must be enabled in the Service Menus.

Passive Cycle

The passive defrost cycle initiates when the refrigerant sensor detects refrigerant temperature below the defrost set point. At this time, the heat pump compressor stops. The heat pump evaporator fan will continue to run, and will draw air over the evaporator fins for about 15 minutes.

If the refrigerant sensor detects a temperature above the defrost stop temperature, the compressor will restart. If defrost stop temperature is not reached within 15 minutes the unit will shut down and display a “Low Ambient Temp” alarm.

Note: The efficiency of a heat pump decreases as air temperature decreases. For maximum efficiency, operate the heat pump during the warmest time of day.

Run Time Counters

Details of the Run Time Counter abbreviations are listed below:

COMP = COMPRESSOR

FAN = EVAPORATOR FAN

REV VLV = REVERSING VALVE (COOLING CYCLE)

FLT PMP = FILTER PUMP (AUTOSET/EXTEND FEATURE)

DEFROST = DEFROST FEATURE

RUN TIME = total time of the current cycle

LOG TIME = accumulated time of all cycles since the last time the unit was powered on

CYCLES = number of cycles since the last time the unit was powered on

WARRANTY HOURS = accumulated time of all cycles over the lifespan of the unit

WARRANTY CYCLES = number of cycles over the lifespan of the unit

Press the UP and DOWN arrows to scroll through the Timers and Counters. The last screen provides an option to reset the Run Time, Log Time and Cycles counters. The Warranty Hours and Warranty Cycle Counter cannot be reset.

Locking the Control Panel

1. Heat pump control panel lock-out – To prevent unwanted adjusting or manipulating of the heat pump settings, the control panel can be locked. Once locked, if any button is pressed, the display will read:

HEAT PUMP
CONTROLS LOCKED

- To activate the control panel lockout, press the MENU SELECT and POOL/SPA buttons simultaneously.
- To unlock the control panel, press the MENU SELECT and POOL/SPA buttons simultaneously.

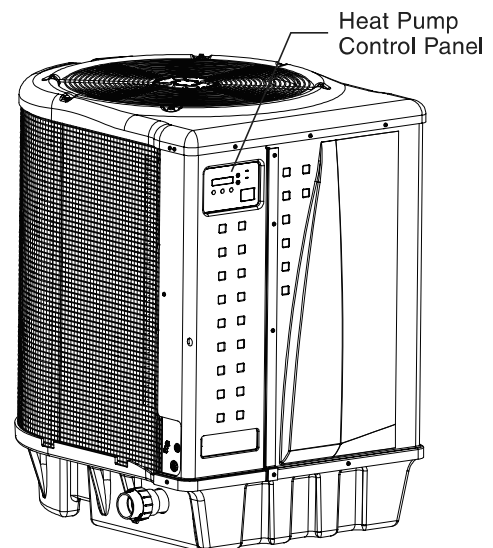

MAINTENANCE

Water Chemistry

Proper chemical balances are necessary for sanitary bathing conditions as well as ensuring your heat pump's long life.

Be sure to keep your chemical and mineral concentration levels within the values indicated in the table below. Failure to maintain proper water chemistry may cause damage to the UltraTemp® Heat Pump and may void the warranty.

Optimal Water Chemistry Ranges

Test	Recommended Level
Free Chlorine <i>or</i>	1.0 to 3.0 ppm (3.0 to 5.0 spa)
Bromine	2.0 to 4.0 ppm (3.0 to 5.0 spa)
pH	7.4 to 7.6
Total Alkalinity (TA) Calcium, Lithium, and Sodium Hydrochlorite	80 to 100 ppm
Total Alkalinity (TA) Sodium Dichlor, Trichlor, Chlorine Gas, and Bromine Compounds	100-120 ppm
Calcium Hardness (CH)	200 to 400 ppm
Cyanuric Acid	30 to 50 ppm
Total Dissolved Solids (TDS)	Less than 2000 ppm
Copper	0 ppm
* Concentration levels taken from "Basic Pool and Spa Technology" published by NSPI (National Spa and Pool Institute).	

Winterizing

CAUTION Failure to properly winterize could damage equipment and will void the warranty. Ensure both the inlet and outlet union are completely disconnected from the heat pump and that plumbing connections are positioned so that all water can freely drain from the heat pump.

In areas where freezing temperatures occur, you should protect your pump, filter, and heat pump from the elements. Perform the following steps to completely drain the heat pump.

1. Turn off the electrical power to the heat pump at the main breaker panel.
2. Shut off the water supply to the heat pump.
3. Disconnect the water inlet and outlet unions located on opposite sides of the heat pump.
4. Cover only the top of the heat pump to prevent debris from falling into the unit. Do not wrap the sides of the heat pump with any plastic or other material that will retain heat or moisture inside the unit.

Spring Start Up

If your heat pump has been winterized, perform the following steps when starting the system in the Spring:

1. Uncover the heat pump and inspect the top and sides for any debris or structural problems.
2. Connect the water inlet and outlet unions on the sides of the heat pump.
3. Turn on the filter pump to supply water to the heat pump. Open the filter air bleeder and circulate water through the system long enough to bleed all the air out of the pool system. Check for leaks in and around the heat pump.
4. Turn on the electrical power to the heat pump at the main breaker panel.

Inspection and Service

Pentair Heat Pumps are designed and constructed to provide long performance life when installed and operated properly under normal conditions.

Periodic inspections are important to keep your heat pump running safely and efficiently through the years. Failure to properly maintain your unit can void the warranty.

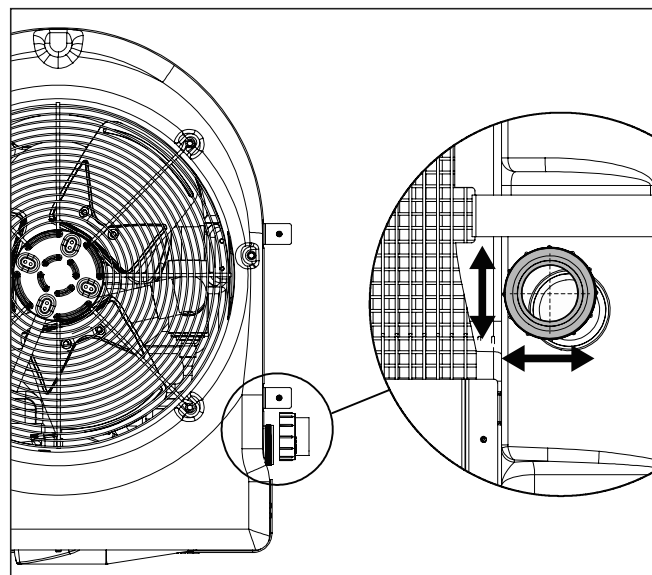

Winterizing Plumbing Connections

Owner Inspection

Pentair recommends that you inspect your heat pump on a continual basis and especially after abnormal weather conditions. The following basic guidelines are suggested for your inspection:

1. Make sure the front of the unit is accessible for future service.
2. Keep the top and surrounding areas of the heat pump clear of all debris.
3. Keep all plants and shrubs trimmed and away from the heat pump.
4. Keep lawn sprinkler heads from spraying on the heat pump to prevent corrosion and damage.
5. If the unit is installed under a roof edge, install a gutter or diverter to prevent excessive water and debris from pouring down into the unit.
6. Do not use this heat pump if any part has been under water. Immediately call a qualified professional technician to inspect the heat pump and replace any part of the control system which has been submerged.

The heat pump will produce condensation (water) while in operation. The heat pump base is designed to allow the condensation to exit through the bottom drain port when the unit is running. The condensation will increase as the outdoor air humidity level increases. Check the following at regular intervals to ensure proper condensate drainage:

1. Visually inspect and clear the bottom drain ports of any debris that could clog the ports.
2. Keep the top air flow discharge and air flow intake area clear of debris so the air flow through the heat pump is not restricted. The cooler discharge air from the top should not accumulate and be drawn into the side air intake coils.
3. Be sure the condensate run-off is properly directed away from the equipment pad to keep it from undermining the pad.
4. Be sure the condensate water does not puddle inside the heat pump. To be sure it is condensate water, check for the absence of chlorine.

During normal operation, the heat pump produces three to five gallons of condensate per hour. If condensate drainage is above this range during operation or if water continues to drain from the base when the heat pump is not in operation for more than an hour, a leak in the internal plumbing may have occurred. Call a qualified heat pump technician to investigate the problem.

Professional Maintenance and Service

The maximum heat output and efficiency of a heat pump is dependent upon the quality and performance of the major components used. Equally important are the environmental conditions (for example, air temperature, humidity, water temperature, and wind).

To maintain maximum performance and efficiency, keep the air coil clean from dirt and debris. It is recommended to clean your air coil once a year by flushing the coil with compressed air or hosing off the coil with a garden hose.

Care should be taken to not bend the coil fins as this will restrict the airflow and lower your heat pump performance. Compressed air can also damage the heat pump coil. **DO NOT USE A PRESSURE CLEANER ON THE UNIT.**

The heat pump should be maintained at least once a year by qualified personnel to maintain maximum performance and efficiency. The unit should be powered off during maintenance.

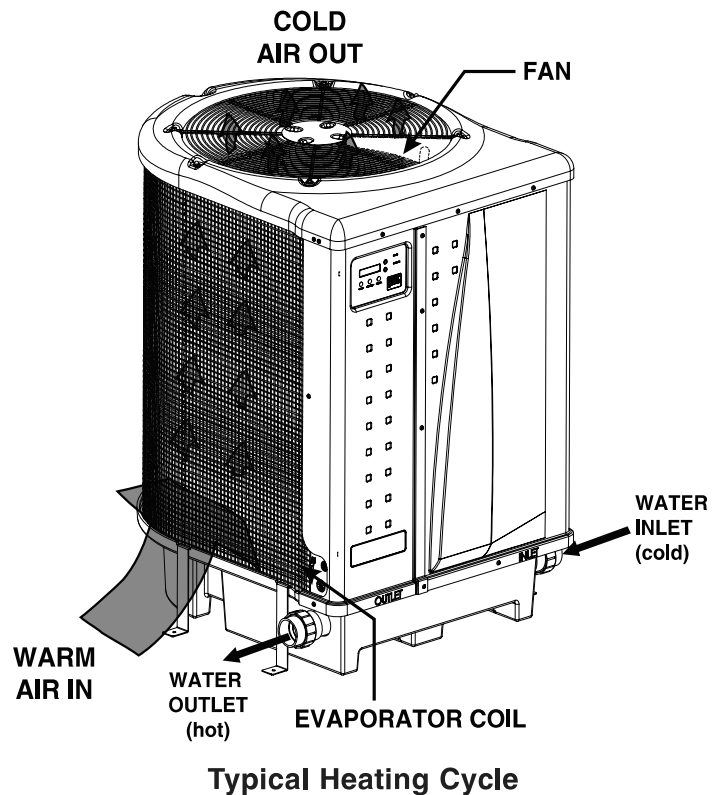

TECHNICAL INFORMATION

Electrical Supply - Voltage Requirements

Models	70	90	110	120	120 H/C	140	140 H/C	120C	140C
	Voltage/Phase/Hz	208-230/1/60	208-230/1/60	208-230/1/60	208-230/1/60	208-230/1/60	208-230/1/60	208-230/1/60	208-230/3/60
Min. Circuit Ampacity (Amp)	33	40	42	42	42	43	43	34	35
Recommended Fuse Size	40	50	50	50	50	50	50	50	50
Max Fuse Breaker Size	50	60	70	70	70	70	70	60	60
Compressor/Fan Motor/System RLA	25/2/27	31/2/33	32/2/34	32/2/34	32/2/34	32/3/35	32/3/35	25/2/27	25/3/28
Compressor/Fan Motor/System LRA	134/4/138	178/4/182	148/4/152	185/4/189	185/4/189	185/11/196	185/11/196	164/4/168	164/11/175
Compressor/Fan Motor/System MCC	39/NA/NA	49/NA/NA	50/NA/NA	50/NA/NA	50/NA/NA	50/NA/NA	50/NA/NA	39/NA/NA	39/NA/NA
Capacity (Btu/h) 80A-80RH-80W *	75,000	90,000	110,000	127,000	125,000	145,000	140,000	122,000	140,000
COP 80A-80RH-80W *	5.9	5.8	6.1	5.7	5.5	5.8	5.6	5.5	5.7
Power Input, KW (80A-80RH-80W) *	3.8	4.6	5.3	6.5	6.6	7.2	7.3	6.5	7.1
Current, Amp (80A-80RH-80W) *	18	21	26	30	31	33	34	19	21
Capacity (Btu/h) 80A-63RH-80W **	70,000	85,000	101,000	120,000	118,000	135,000	132,000	114,000	130,000
COP 80A-63RH-80W **	5.7	5.6	5.8	5.5	5.3	5.6	5.4	5.3	5.5
Power Input, KW (80A-63RH-80W) *	3.6	4.5	5.1	6.4	6.5	7.0	7.2	6.3	7.0
Current, Amp (80A-63RH-80W) *	17	20	25	29	30	32	33	19	21
Capacity (Btu/h) 50A-63RH-80W ***	50,000	60,000	70,000	80,000	80,000	90,000	85,000	76,000	85,000
COP 50A-63RH-80W ***	4	4	4	4	4	4	4	4	4
Power Input, KW (50A-63RH-80W) *	3.6	4.4	5.3	6	6	6.4	6.2	5.7	6.2
Current, Amp (50A-63RH-80W) *	17	19	24	27	28	29	29	18	21
Shipping Weight (lbs) ****	250	250	270	270	278	320	320	280	320
Shipping Size (L x W x H)	43"x34"x39"	43"x34"x39"	43"x34"x51"	43"x34"x51"	43"x34"x51"	43"x34"x46"	43"x34"x46"	43"x34"x51"	43"x34"x46"

* 80A-80RH-80W: 80°F (27°C) Air Temp, 80% RH, 80°F (27°C) Water Inlet Temp.

** 80A-63RH-80W: 80°F (27°C) Air Temp, 63% RH, 80°F (27°C) Water Inlet Temp.

*** 50A-63RH-80W: 50°F (10°C) Air Temp, 63% RH, 80°F (27°C) Water Inlet Temp.

**** Add 50 lbs. for Pallet and Packaging.

COP = Coefficient of Performance

If voltage drops below 208V, this may damage the heat pump and void the warranty. Take proper steps to ensure correct voltage at the heat pump during operation.

Temperature Resistance Chart

*Temperature Resistance Chart									
°F	OHMS	°F	OHMS	°F	OHMS	°F	OHMS	°F	OHMS
0	85,387	51	19,377	66	13,136	81	9,076	96	6,382
10	62,479	52	18,870	67	12,809	82	8,861	97	6,238
20	46,225	53	18,377	68	12,491	83	8,651	98	6,097
30	34,561	54	17,899	69	12,182	84	8,447	99	5,960
40	26,100	55	17,435	70	11,882	85	8,249	100	5,827
41	25,391	56	16,985	71	11,589	86	8,056	101	5,697
42	24,704	57	16,548	72	11,305	87	7,867	102	5,570
43	24,037	58	16,123	73	11,029	88	7,684	103	5,446
44	23,391	59	15,711	74	10,761	89	7,506	104	5,326
45	22,764	60	15,310	75	10,500	90	7,333	105	5,208
46	22,156	61	14,921	76	10,246	91	7,164	106	5,094
47	21,566	62	14,543	77	9,999	92	6,999	107	4,982
48	20,993	63	14,176	78	9,758	93	6,839	108	4,873
49	20,438	64	13,820	79	9,525	94	6,683	110	4,664
50	19,900	65	13,473	80	9,297	95	6,530	120	3,758

The table below should be used by trained air-conditioning and refrigeration service people.

The table below **should not be used for adjusting the charge in the system.**

Use of interpolation or extrapolation of the table data may not be appropriate unless it is closely matched by the ambient and water flow conditions.

Air: 80F, 80%RH		Water: 80F, 45-50gpm	
Model	Discharge Pressure (psig)	Suction Pressure (psig)	Superheat (F)
HP500	359	134	14
HP700	348	132	14
HP900	355	142	10
HP1200	367	141	8
HP1200R	367	141	8
UltraTemp 70	329	156	19
UltraTemp 90	340	147	20
UltraTemp 110	343	164	11
UltraTemp 120	350	157	9
UltraTemp 120 H/C	378	157	10
UltraTemp 140	352	168	12
UltraTemp 140 H/C	377	170	10
UltraTemp 120C	354	150	12
UltraTemp 140C	365	168	13

Air: 80F, 63%RH		Water: 80F, 45-50gpm	
Model	Discharge Pressure (psig)	Suction Pressure (psig)	Superheat (F)
HP500	352	125	11
HP700	341	123	11
HP900	348	132	8
HP1200	360	131	6
HP1200R	360	131	6
UltraTemp 70	323	149	17
UltraTemp 90	330	138	18
UltraTemp 110	337	153	9
UltraTemp 120	344	146	7
UltraTemp 120 H/C	368	146	8
UltraTemp 140	345	158	10
UltraTemp 140 H/C	369	158	10
UltraTemp 120C	346	146	10
UltraTemp 140C	358	160	11

Air: 50F, 63%RH		Water: 80F, 45-50gpm	
Model	Discharge Pressure (psig)	Suction Pressure (psig)	Superheat (F)
HP500	330	83	5
HP700	320	81	4
HP900	325	85	4
HP1200	322	86	3
HP1200R	322	86	3
UltraTemp 70	313	97	7
UltraTemp 90	312	93	4
UltraTemp 110	324	92	4
UltraTemp 120	330	90	3
UltraTemp 120 H/C	336	90	3
UltraTemp 140	325	98	3
UltraTemp 140 H/C	327	100	3
UltraTemp 120C	318	89	4
UltraTemp 140C	320	97	4

Air: 80F, 63%RH		Water: 104F, 45-50gpm	
Model	Discharge Pressure (psig)	Suction Pressure (psig)	Superheat (F)
HP500	457	137	7
HP700	445	142	8
HP900	450	141	5
HP1200	478	135	6
HP1200R	478	135	6
UltraTemp 70	430	164	11
UltraTemp 90	440	152	8
UltraTemp 110	453	159	5
UltraTemp 120	450	152	4
UltraTemp 120 H/C	474	152	4
UltraTemp 140	461	163	8
UltraTemp 140 H/C	465	165	6
UltraTemp 120C	450	150	7
UltraTemp 140C	463	165	8

RH = Relative Humidity

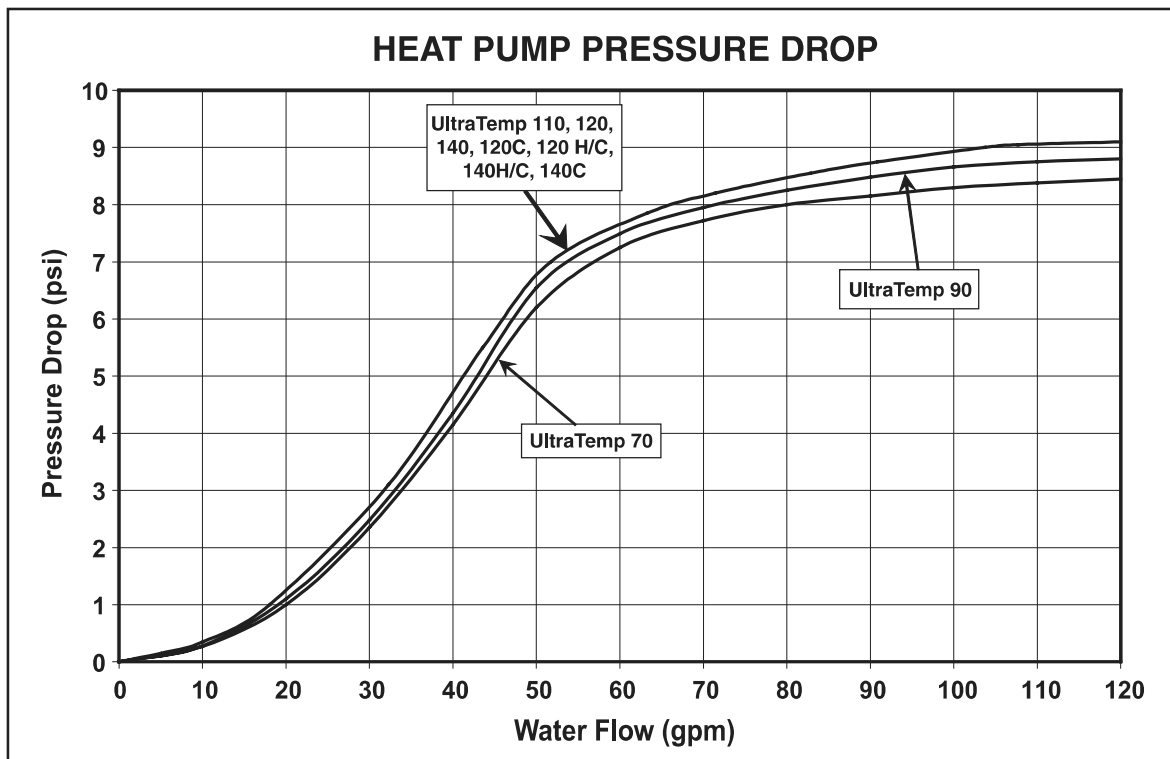

TROUBLESHOOTING

⚠ WARNING



RISK OF ELECTRICAL SHOCK OR ELECTROCUTION. Improper installation will create an electrical hazard which could result in death or serious injury to pool users, installers, or others due to electrical shock, and may also cause damage to property. Do NOT attempt any internal adjustments inside the heater.

1. Keep your hands and hair clear of the fan blades to avoid injury.
2. If you are not familiar with your pool filtering system and heater:
 - a. Do NOT attempt to adjust or service without consulting your dealer, professional pool or air conditioning contractor.
 - b. Read the entire Installation & User's Guide before attempting to use, service or adjust the heater or pool filtering system. The water pressure switch should be adjusted to turn the heater off when the pump is off. Setting the switch to close at too low of a flow can damage the appliance. Adjust the switch to turn the heater off, not on.

Always turn power to the unit OFF before servicing or repair.

Note: Any service must be done by an authorized service agency person.

Problem or Symptoms	Possible Cause	Corrective Action
HIGH WATER TEMP Alarm: Water temperature above 108°F (42.2°C).	Bad thermistor or bad control board.	Test water temp to see if it is correct, if not, use the 10k ohm resistance test to verify thermistor. If bad, replace thermistor. If good, replace control board.★
LOW WATER TEMP Alarm: Water temperature below 40°F (4.4°C).	Bad thermistor or bad control board.	Test water temp to see if it is correct, if not, use the 10k ohm resistance test to verify thermistor. If bad, replace thermistor. If good, replace control board.★
	Debris is shorting the connections.	Remove debris or replace PCB.
LOW WATER FLOW Alarm: The pressure switch sensing water flow is open.	Water circulation pump not on.	Verify water circulation pump is on.
	Insufficient water flow.	Dirty or worn filters or clogged lint traps. Verify filter is clean, backwash if necessary to clean entire filter system or replace filter element if needed. Inspect & clean pump impeller. Adjust Plumbing valves. Repair suction air leaks.
	External bypass open.	Make sure external water bypass around heat pump is closed.
	Bad water pressure switch.	With water flowing, check resistance of water pressure switch, if open, replace switch.
REMOTE POOL SPA Alarm: Pool and Spa remote inputs are simultaneously energized.	Remote pool, spa, and common spade terminals on the back of the control board are all energized.	Modify automation control output so that only either the pool and common or spa and common terminals are energized.
WATER THERM SHORT Alarm: Water temperature sensor circuit is shorted.	Bad thermistor or bad control board.	Use the 10k ohm resistance test to verify thermistor. If shows shorted, replace thermistor. If good, replace control board.★
WATER THERM OPEN Alarm: Water temperature sensor circuit is open.	Bad thermistor, or bad control board.	Use the 10k ohm resistance test to verify thermistor. If shows open, replace thermistor. If good, replace control board.★
SUCTION TH SHORT Alarm: Defrost refrigerant temperature sensor circuit is shorted.	Bad thermistor or bad control board.	Use the 10k ohm resistance test to verify thermistor. If shows shorted, replace thermistor. If good, replace control board.★
SUCTION TH OPEN Alarm: Defrost refrigerant temperature sensor circuit is open.	Bad thermistor or bad control board.	Use the 10k ohm resistance test to verify thermistor. If shows an open, replace thermistor. If good, replace control board.★
BROWNOUT Alarm: The 24 VAC supply voltage to the control board is low. CAUTION: High Voltage Checks. Observe extreme caution or call dealer or factory for advice before attempting to Troubleshoot Electrical Box.	Bad transformer	Supply voltage to the transformer should be between 208 and 260 volts. Transformer should output between 24 and 28 volts. If below this range, replace transformer.
	Insufficient supply voltage to the heat pump.	Check supply voltage to the heat pump. Supply voltage should be between 208 and 260 volts. Check to see if a phase is out. Should have 120 volts to ground and 240 volts across power legs. A boost transformer may be needed closer to the heat pump to get voltages within proper range.

(*) Refer to 10K Ohm Temperature Resistance Chart on page 25.

Problems or Symptoms	Possible Cause	Corrective Action
HIGH REFRIG Alarm: Refrigerant high pressure switch is open.	Water circulation pump inactive.	Verify water pump is on.
	Insufficient water flow.	Verify filter and skimmers are clean, backwash if necessary. Minimum flow 30 GPM [113.6 LPM].
	External bypass open.	Verify external water bypass around heat pump is closed. Also make sure all other valves are open or in the proper positions to allow proper water flow through heat pump.
	Bad refrigerant high pressure switch.	Check resistance of switch, if open, replace switch.
	TXV Stuck Closed.	<ol style="list-style-type: none"> 1. Disconnect TXV bulb from suction line (SL), have it in your hand, if pressures go back to normal, then reinstall the bulb on suction line (it may have some debris stuck in the port). For adjustable TXVs open adjustable valve, it may remove the debris and set it back to original position. 2. If (1) does not work, recover the charge, remove bulb from SL, unscrew TXV head, shake it, if rattles, replace head (PN KT-45-ZGA), if not, replace TXV and filter dryer and charge appropriately.
	Other Possibilities:	Check Water level in pool. This condition may appear if the heat pump has NOT been operated for an extended period. To Clear this condition, cycle the heat pump on and off up to 3 times. If this does not correct problem, call for service.
	Other Possibilities. Low or restricted water flow through heater. Dirty or worn filters or clogged lint traps. Clogged filter pump impeller. Improper plumbing valve settings. Suction leak allowing air into the water flow. Low water flow when switched to spa mode. Unit is plumbed backwards. Heat exchanger clogged with debris. Internal bypass valve damaged or clogged with debris.	Clean entire filtering system and or replace filter element. Inspect & clean pump impeller. Adjust all plumbing valves. Repair suction air leaks, grease pump lid O-ring. Replace filter. Wrong filter pump pipe size. Automatic pool vacuum causing restriction. Call your dealer or factory for advice if above does not solve the problem.
	Unit overcharged.	Reclaim charge. Recharge with appropriate nameplate charge.
LOW REFRIG Alarm: Refrigerant low pressure switch is open.	Compressor Thermal Protector tripped open.	<p>Check Thermal Protector located on top of the compressor. The Thermal Protector will trip if the compressor reaches a temperature greater than 240°F (115.6°C). It will reset when the temperature drops below 170°F (76.7°C).</p> <p>If the corrective actions above do not resolve the HIGH REFRIG Alarm, check the resistance of the Thermal Protector while the unit is powered off, if the circuit is open, replace the Thermal Protector.</p> <p>*This feature is only available on heat pumps equipped with LG compressors starting 11/1/2020, except the UT70 model, which uses an internal Thermal Protection device.</p>
	Low refrigerant in system.	Find source of refrigerant leak and fix. Pull vacuum and recharge.
	Air and water temperatures too cold to operate the heat pump.	Wait until temperatures warm up and see if unit operates.
	Bad refrigerant low pressure switch.	Check resistance of switch with a full charge, if open, replace switch.
	Faulty fan.	Check the capacitor and fan motor. Replace either one if it is faulty. Check the fan blade and make sure it is not slipping or broken. If so, replace the fan.
	TXV Stuck Closed.	<ol style="list-style-type: none"> 1. Disconnect TXV bulb from suction line (SL), have it in your hand, if pressures go back to normal, then reinstall the bulb on suction line (it may have some debris stuck in the port). For adjustable TXVs open adjustable valve, it may remove the debris and set it back to original position. 2. If (1) does not work, recover the charge, remove bulb from SL, unscrew TXV head, shake it, if rattles, replace head (PN KT-45-ZGA), if not, replace TXV and filter dryer and charge appropriately.
Insufficient airflow through air coil	Remove surrounding debris or shrubs or heat pump maintenance by qualified personnel.	

Problem or Symptoms	Possible Cause	Corrective Action
LOW AMBIENT TEMP Alarm: Refrigerant temperature sensor indicates air temperature is too low for heat pump operation.	Defrost cycle did not complete within allotted time	Wait until ice melts from evaporator coil and/or air temperatures rise.
	Bad thermistor.	View reported suction temperature on control board. Use 10k ohm resistance test to verify thermistor.
FIVE ALARMS: Indicates 5 faults have occurred in 1 hour. This fault will automatically reset in one hour or can be manually reset by pressing the ON/OFF button.	5 alarms of any kind within one hour.	Press the ON/OFF button to clear the alarm. Check Heat Pump over the next few minutes/hours to see if alarm appears again. This alarm most likely caused the five alarms in one hour.
Unable to turn Heat Pump ON. Display is Blank. Unit will NOT start.	Control failure. No power supply to heater. Tripped breaker or blown fuse. Faulty Transformer. Incorrect Wiring.	Reset breaker. Replace fuse. Call dealer or factory for advice before attempting to replace parts. Replace Transformer. Check wiring.
Unit power is ON, green light ON, and Set Temperature is above Actual. Unit will NOT start to heat or cool. No Alarms.	Remote feature enabled, but no controlling device hook-up. Control failure. Heat pump not turned on.	Check to see if the Remote feature on the Control Board is enable. Disable if needed. See page 18 for more information on disabling Remote function. Call dealer or factory for advice before attempting to replace parts. Replace Control Board.
Unit power is ON, green light ON, and Set Temperature is above Actual. Unit will NOT start to heat. No Alarms.	Heat Pump pool/spa selection mode incorrect. The thermostat is malfunctioning. Control Board Failure.	Check to see if heat pump is in correct active pool/spa mode by pressing the pool/spa button. If active mode is spa, but trying to heat/cool pool press pool/spa button again to change the active mode to pool. If active mode is Pool, but want spa heat change active mode to spa. Call dealer or factory for advice before attempting to replace parts. Replace thermostat. Replace Control Board.
Unit power is ON, green light ON, and Set Temperature is above Actual. Unit cycles on and off, i.e. Compressor cuts on briefly and then off after Five minute delay before set point is reached.	Faulty Compressor. Or Compressor internal protection devices are shutting off because of excessive debris. Faulty Compressor contactor. Incorrect wiring. Control Board Failure. Internal bypass valve damaged or clogged with debris. Heat exchanger clogged with debris. Suction leak allowing air into the water flow. Unit is plumbed backwards.	Clean entire filtering system and or replace filter element. Inspect & clean pump impeller. Adjust all plumbing valves. Repair suction air leaks, grease pump lid O-ring. Replace filter. Wrong filter pump pipe size. Automatic pool vacuum causing restriction. Call your dealer or factory for advice if corrective action does not solve the problem. Possible Compressor's internal relief valve or overload protection device is faulty. Call dealer or factory for advice before attempting to replace parts. Replace Compressor.
Unit is forming ICE or Frost on the outer air coil, usually at the bottom.	Discharge air flow is restricted. Discharge air is accumulating and being drawn back through the outer air coil. The fan is obstructed, low air flow. Sprinklers spraying on the outer air coil during cooler temperatures. Outer air coil clogged with debris. Plants too close to heater, blocking discharge air flow. Low refrigerant pressure caused by a Refrigerant leak. Possible malfunctioning of the internal low refrigerant pressure switch. Check Alarm Status on Control Board for LOW REFRIG Alarm.	The outside air temperature too low and Defrost feature is NOT enable. Malfunctioning Defrost Thermistor. Make sure heater is installed with the required placement clearances for air flow and roof clearance. Do NOT install indoors. Make sure that your sprinklers do NOT spray on the heater in any way what so ever. If ice forms on the outer coil, shut the heater off and allow ice to thaw. You may use water at low pressure to thaw ice build up on the outer coil, shut the heater off when doing so. Call your dealer or factory for advice corrective action does not solve the problem.
Unit power is ON, and Set Temperature is above Actual. Fan is NOT Turning. No Alarms.	Faulty Fan Relay. Faulty Capacitor. Faulty Fan Motor. Control Board Failure. Incorrect wiring.	Call dealer for advice before attempting to replace parts. Replace Fan relay. Replace Capacitor, Replace Fan motor. Replace Control Board.
Fan is turning, no cool air discharge out of top of heater. Unit ON, and Set Temperature is above Actual, but Unit is not heating. No Alarms.	Heat Pump is in the five minute safety delay and Compressor has not started. Faulty Compressor. Faulty Capacitor. Compressor contactor is stuck open. Control Board failure. Incorrect wiring.	Call dealer or factory for advice before attempting to replace parts. Replace Capacitor. Replace Control board. Replace Contactor. Replace Compressor.

Problem or Symptoms	Possible Cause	Corrective Action
Spa will not heat to maximum temperature of 104°F (40°C). Thermostat is turned all the way up. OR Spa is heating very slowly.	Low or restricted water flow through heater. Dirty or worn filters or clogged lint traps. Clogged filter pump impeller. Improper plumbing valve settings. Suction leak allowing air into the water flow. Low water flow when switched to spa mode or the control is not in spa mode. Unit is plumbed backwards. Heat exchanger clogged with debris. Internal bypass valve damaged or clogged with debris. Your spa thermometer is not reading the correct temperature. Air blower is running. Venturi air inlets are open. It is very cold outside. Spa pump is not running.	Clean entire filtering system and or replace filter element. Inspect & clean pump impeller. Adjust all plumbing valves. Repair suction air leaks, grease pump lid O-ring. Shut off air blower and or Venturi inlets that allow air turbulence in the spa. Use a cover while heating the spa. Outside air temperature too cold. Set spa pump timer for longer time. Call your dealer for advice. Call the factory for advice.
Pool is heating very slowly. Pool is not getting up to temperature.	“Low or restricted water flow through heater. Dirty or worn filters or clogged lint traps. Clogged filter pump impeller. Improper plumbing valve settings. Suction leak allowing air into the water flow. It is cold outside. Pool pump timer is not set for a long enough running period. Pool is not covered. High wind speed over pool. Shaded pool area.”	Clean entire filtering system and or replace filter element. Inspect & clean pump impeller. Adjust all plumbing valves. Repair suction air leaks, grease pump lid O-ring. Use a pool cover. Place a wind break around pool. Set pool pump timer longer. Call your dealer for advice. Call the factory for advice.
Higher than Normal Head Pressure, lower than normal suction pressure with high superheat and very cold or frosty distributor tubes, may have no Alarm.	TXV stuck closed.	1. Disconnect TXV bulb from suction line (SL), have it in your hand, if pressures go back to normal, then reinstall the bulb on suction line (it may have some debris stuck in the port). For adjustable TXVs open adjustable valve, it may remove the debris and set it back to original position. 2. If (1) does not work, recover the charge, remove bulb from SL, unscrew TXV head, shake it, if rattles, replace head (PN KT-45-ZGA), if not, replace TXV and filter dryer and charge appropriately.
Lower than Normal Head Pressure, higher than normal suction pressure with cold suction line and compressor and no superheat, may have no Alarm.	TXV stuck open.	1. Check to see if TXV bulb is firmly attached to suction line, if loose, attach firmly by tightening the clamp over the bulb and suction line. 2. If (1) above does not work, reclaim charge and replace TXV and filter dryer with nameplate charge.
Unusually higher than normal current.	TXV stuck closed/partially closed, insufficient water flow, system overcharged.	See Possible Cause column for: TXV stuck closed, Insufficient water flow, and Unit overcharged.
Low current with high superheat.	Unit undercharged.	Find source of refrigerant leak and fix. Pull vacuum and charge.
Unit runs, but breaker trips continuously.	Electrical issue.	Contact certified electrician.

Problems and Corrective Action (3 Phase Units Only)		
Problem or Symptoms	Possible Cause	Corrective Action
Unable to turn Heat Pump ON. Display is Blank. Unit will NOT start.	Incorrect Wiring.	Check the Light on Phase Monitor inside the electrical box. If red, switch two of the Input wires. Any two of the three can be switched.
	Faulty Phase Monitor.	Call dealer or factory for advice before attempting to replace parts. Replace Phase Monitor.
	Loose wire on Phase Monitor, either from the supply input power or the output side.	Check the Light on Phase Monitor inside the electrical box. If the Light is Red, fix the supply power loose end. If the Light is green, fix the output loose wire.
Compressor making a loud or unusual noise or sounds during operation. Fan is turning, no cool air discharge out of top of heater. Unit ON, and Set Temperature is above Actual, but Unit is not heating.	Compressor running Backwards. This usually happens if the compressor wire harness is disconnected for possible repair or replacement.	Switch any two of the three wires on the compressor side of the contactor.

[BLANK PAGE]

REPLACEMENT PARTS

Illustrated Parts View

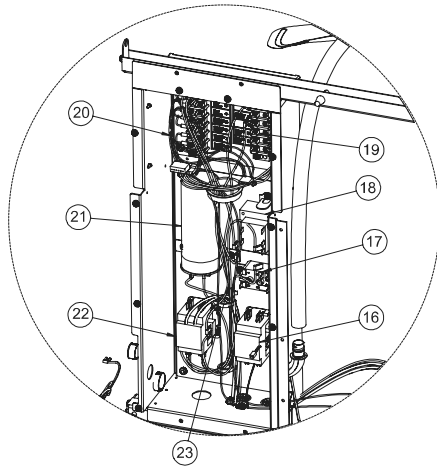

DETAIL B – Single Phase Models

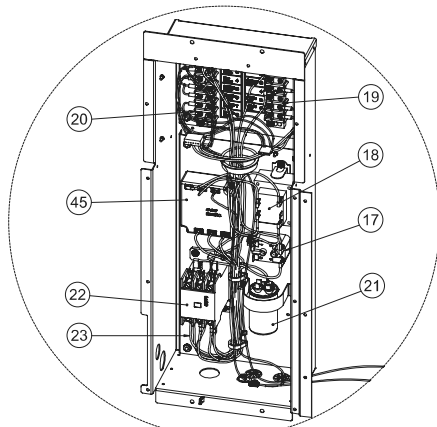

DETAIL B – Three Phase Models

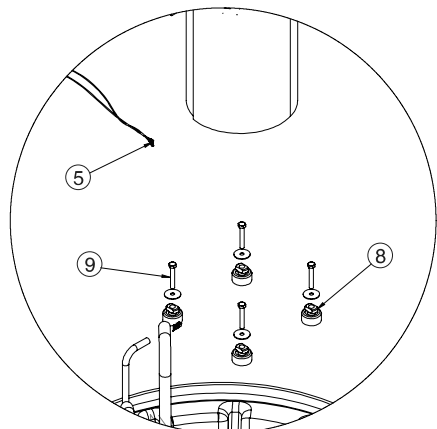

DETAIL C

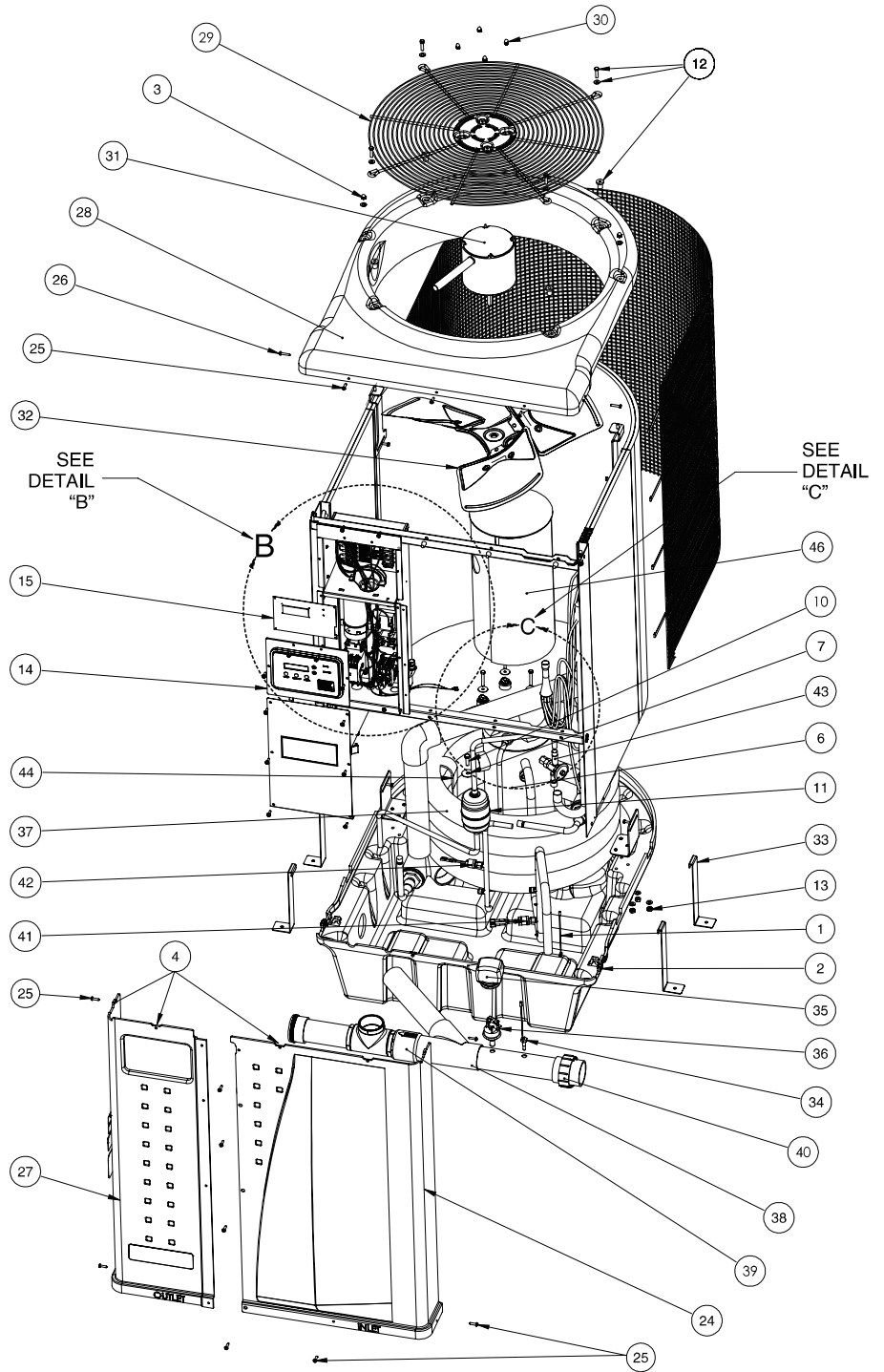

Parts List

ITEM	PART NO.	DESCRIPTION
1	473665	Probe Thermistor Defrost Sensor
2	470284	Nut, J-Clip
3	473285	Nut, 1/4 - 20 S/S Acorn
4	470281	Nut, U-Clip
5	473732 476233	Wire Harness, Emerson Compressor (3PH - 60Hz) Wire Harness, LG Compressor (1PH-60Hz)
6	476230z 476229z 474011z 476228z 476227z	Compressor Kit, Scroll ARA083 (Models 120Q, 120H/C, 140, 140H/C) Compressor Kit, Scroll ARA072 (Model 110) Compressor Kit, Scroll ZP83 (3PH Models 120C, 140C) Compressor Kit, Scroll ARA061 (Model 90) Compressor Kit, Scroll ABG049 (Model 70)
7	473295	Fender Washer
8	476232z	Compression Isolation Kit, Grommet and Spacer (1 Set)
9	473745	Bolt 5/16 - 18 x 1.75" S/S
10	98219800	Bolt 5/16 - 18 x 1" S/S
11	473121 473139	Drier (All Models except 120H/C, 140H/C) Drier (Models 120H/C, 140H/C)
12	470441	Fan Guard Fastener Kit
13	071406	Nut, 1/4 - 20 Hex S/S
14	472734	Bezel, Control Board w/ Label
15		AutoSet Control Board, High
16	473603	Pump Contactor, AutoSet
17	473150	Fan Relay
18	473155	Transformer
19	473422	Wire Harness Terminal Block - Fan, Compressor
20	473315	Wire Harness Terminal Block - Sensors
21	473731z 473154	Capacitor (All Models except 120C, 140C) Capacitor (3PH Models 120C, 140C)
22	473778	Contactor, Heat Pump
23	475112 474021	Wire Harness, Main (All Single Phase Models) Wire Harness, Main (3PH Models 120C, 140C)
24	473742 474194 473412 474265	Panel, Front Right, 36" Almond Panel, Front Right, 36" Black Panel, Front Right, 24" Almond (Models 70, 90) Panel, Front Right, 24" Black (Models 70, 90)
25	470159 470198	Screw #10 x 0.75" Pan Head Phillips, Almond Screw #10 x 0.75" Pan Head Phillips, Black
26	475263 475264	Screw #10 x 0.75" Pan Head Square Drive, Almond Screw #10 x 0.75" Pan Head Square Drive, Black
27	473755 474196 474203 474267	Panel, Front Left w/ Decal, 36" Almond Panel, Front Left w/ Decal, 36" Black Panel, Front Left w/ Decal, 24" Almond Panel, Front Left w/ Decal, 24" Black
28	473773 474193 475273 475274	Panel, Top, Almond Panel, Top, Black Panel, Top, Almond (Model 120Q) Panel, Top, Black (Model 120Q)

ITEM	PART NO.	DESCRIPTION
29	473786	Guard, Fan
30	470439	Nut #10-32 S/S Acorn
31	473785 474323z	Fan Motor w/ Acorn Nut Kit Fan Motor w/ Acorn Nut Kit (Models 140, 140C, 140H/C)
32	473783 474322 475271	Fan Blade (60Hz) Fan Blade (Models 140, 140C, 140H/C) Fan Blade (Model 120Q)
33	470137	Tie Down Bracket
34	471566	Probe Thermistor - Water Temperature
35	473606	Water Pressure Switch Boot
36	473605	Water Pressure Switch
37	475193z 475219z	Titanium Heat Exchanger, 4.5 Wrap (All Models Except 70) Titanium Heat Exchanger, 3.5 Wrap (Model 70)
-	474270z	Heat Pump Coil Repair Kit
38	475176z	Manifold Bypass Kit
39	R172305	Water Bypass Check Valve
40	473381	Union, PVC 2"
41	473656	Switch, Low Pressure
42	473744	Switch, High Pressure
43	473787 473999 474242 474327	Thermostatic Expansion Valve (Models 110, 120Q, 120C) Thermostatic Expansion Valve (Model 120H/C) Thermostatic Expansion Valve (Models 70, 90) Thermostatic Expansion Valve (Models 140, 140C, 140H/C)
44	475194 475195	Heat Exchanger Strap, Right Side Heat Exchanger, Left Side
45	474089	Phase Monitor
46	475230	Compressor Blanket
-	473135	Reversing Valve Assembly (Models 120H/C, 140H/C)
-	473432	Reversing Solenoid (Models 120H/C, 140H/C)
-	474237	Retention Clip, Compressor Power Cord
-	474321	3" Receiver (Models 140, 140C, 140H/C)
-	473054z	Coil Guard
-	475232	Male Hose Barb 5/8" x 1/2" NPT
-	472409	Refrigerant Valve Core
-	355330	O-ring, Union
-	476254	LG Thermal Protector
-	473603z	AutoSet Accessory Kit

(-) Not Shown

SAVE THESE INSTRUCTIONS



1620 HAWKINS AVE., SANFORD, NC 27330 • (919) 566-8000
10951 WEST LOS ANGELES AVE., MOORPARK, CA 93021 • (805) 553-5000

All indicated Pentair trademarks and logos are property of Pentair. Third party registered and unregistered trademarks and logos are the property of their respective owners.

© 2023 Pentair. All rights reserved. WWW.PENTAIR.COM



P/N 474099 REV. AA 5/4/23